



MODELS:

942297G

FastCat-FX541V KAW W/36 SIDE DISCHARGE

942298G

FastCat-FX600V KAW W/48 SIDE DISCHARGE

942299G

FastCat-FX651V KAW W/52 SIDE DISCHARGE

942302G

FastCat-FX600V KAW W/42 SIDE DISCHARGE

942404G

FastCat-627cc VANGUARD B&S W/61 SIDE DISCHARGE

942405G

FastCat-FX691V KAW W/61 SIDE DISCHARGE

MAN 4165951
REVA 10-2010



PARTS / OPERATOR'S MANUAL

**CALIFORNIA
Proposition 65 Warning**

Diesel engine exhaust and some of its constituents are known to the State of California to cause cancer, birth defects and other reproductive harm.

▲ WARNING

The engine exhaust from this product contains chemicals known to the State of California to cause cancer, birth defects or other reproductive harm.

Californie Proposition 65 Avertissement

Les échappements des moteurs diesel et certains de leurs composants sont reconnus par l'Etat de Californie pour être cancérigènes, provoquer des défauts congénitaux et d'autres dangers en matière de reproduction.

▲ AVERTISSEMENT

L'émission du moteur de ce matériel contient des produits chimiques que l'Etat de Californie considère être cancérigènes, provoquer des défauts congénitaux et d'autres dangers en matière de reproduction.

**California Advertencia
de la Proposición 65**

El estado de California hace saber que los gases de escape de los motores diesel y algunos de sus componentes producen cáncer, defectos de nacimiento y otros daños en el proceso de reproducción humana.

▲ ADVERTENCIA

El estado de California hace saber que los gases de escape de este producto contienen productos químicos que producen cáncer, defectos de nacimiento y otros daños en el proceso de reproducción humana.

**CALIFORNIA
Proposition 65 Warning**

Battery posts, terminals, wiring insulation, and related accessories contain lead and lead compounds, chemicals known to the State of California to cause cancer and birth defects or other reproductive harm.
WASH HANDS AFTER HANDLING.

FastCat Pro

IMPORTANT MESSAGE

Thank you for purchasing this Schiller Grounds Care, Inc. product. You have purchased a world class mowing product, one of the best designed and built anywhere.

This machine comes with an Operation and Safety Manual. The useful life and good service you receive from this machine depends to a large extent on how well you read and understand these manuals. Treat your machine properly, lubricate and adjust it as instructed, and it will give you many years of reliable service.

Your safe use of this Schiller Grounds Care, Inc. product is one of our prime design objectives. Many safety features are built in, but we also rely on your good sense and care to achieve accident-free operation. For best protection, study the manual thoroughly. Learn the proper operation of all controls. Observe all safety precautions. Follow all instructions and warnings. Do not remove or defeat any safety features. Make sure those who operate this machine are as well informed and careful in its use as you are.

See a Schiller Grounds Care, Inc. dealer for any service or parts needed. Schiller Grounds Care, Inc. service ensures that you continue to receive the best results possible from Schiller Grounds Care, Inc. products. You can trust Schiller Grounds Care, Inc. replacement parts because they are manufactured with the same high precision and quality as the original parts.

Schiller Grounds Care, Inc. designs and builds its equipment to serve many years in a safe and productive manner. For longest life, use this machine only as directed in the manuals, keep it in good repair and follow safety warnings and instructions. You'll always be glad you did.

Schiller Grounds Care, Inc.
One Bob Cat Lane
Johnson Creek, WI 53038-0469

TABLE OF CONTENTS	FIGURES	PAGE
SAFETY.....		2-8
SET-UP INSTRUCTIONS.....		9-10
LABELS.....		11-14
CONTROLS.....		15-18
PRE-OPERATION CHECKLIST.....		19
OPERATION.....		20-22
MAINTENANCE CHART.....		23
MAINTENANCE RECORD.....		24
MAINTENANCE.....		25-31
ADJUSTMENTS.....		32-36
BELT REPLACEMENT.....		39-38
PARTS SECTION.....		39
FRAME-ENGINE/CLUTCH ASSY.....	FIGURE 1.....	40, 41
TRANSAXLE ASSY.....	FIGURE 2.....	42, 43
FUEL TANK/BUMPER & CONTROL PANEL.....	FIGURE 3.....	44, 45
FUEL VALVE & COVER PLATE.....	FIGURE 4.....	46, 47
DECK LIFT ASSEMBLY.....	FIGURE 5.....	48, 49
CASTER ASSEMBLY.....	FIGURE 6.....	50, 51
KICKPLATE/SEAT ASSEMBLY.....	FIGURE 7.....	52, 53
STEERING.....	FIGURE 8.....	54, 55
PARKING BRAKE.....	FIGURE 9.....	56, 57
WIRE HARNESS.....	FIGURE 10.....	58, 59
36" SIDE DISCHARGE.....	FIGURE 11.....	60, 61
42" SIDE DISCHARGE.....	FIGURE 12.....	62, 63
48" SIDE DISCHARGE.....	FIGURE 13.....	64, 65
52" SIDE DISCHARGE.....	FIGURE 14.....	66, 67
61" SIDE DISCHARGE.....	FIGURE 15.....	68, 69
BELTS-CUTTERDECK.....	FIGURE 16.....	70, 71
DECALS-POWERUNIT.....	FIGURE 17.....	72, 73

NOTICE !!!

Unauthorized modifications may present **extreme** safety hazards to operators and bystanders and could also result in product damage.

Schiller Grounds Care, Inc. strongly warns against, rejects and disclaims any modifications, add-on accessories or product alterations that are not designed, developed, tested and approved by Schiller Grounds Care, Inc Engineering Department. Any Schiller Grounds Care, Inc. product that is altered, modified or changed in any manner not specifically authorized after original manufacture—including the addition of “aftermarket” accessories or component parts not specifically approved by Schiller Grounds Care, inc.—will result in the Schiller Grounds Care, Inc. warranty being voided.

Any and all liability for personal injury and/or property damage caused by any unauthorized modifications, add-on accessories or products not approved by Schiller Grounds Care, Inc. will be considered the responsibility of the individual(s) or company designing and/or making such changes. Schiller Grounds Care, Inc. will vigorously pursue full indemnification and costs from any party responsible for such unauthorized post-manufacture modifications and/or accessories should personal injury and/or property damage result.



This symbol means:
ATTENTION!
BECOME ALERT!

Your safety and the safety of others is involved.

Signal word definitions:

The signal words below are used to identify levels of hazard seriousness. These words appear in this manual and on the safety labels attached to Schiller Grounds Care, Inc. machines. For your safety and the safety of others, read and follow the information given with these signal words and/or the symbol shown above.

DANGER

DANGER indicates an imminently hazardous situation which, if not avoided, **WILL** result in death or serious injury.

WARNING

WARNING indicates a potentially hazardous situation which, if not avoided, **COULD** result in death or serious injury.

CAUTION

CAUTION indicates a potentially hazardous situation which, if not avoided, **MAY** result in minor or moderate injury. It may also be used to alert against unsafe practices or property damage.

CAUTION

CAUTION used without the safety alert symbol indicates a potentially hazardous situation which, if not avoided, **MAY** result in property damage

Schiller Grounds Care, Inc.

One Bobcat Lane
Johnson Creek, WI 53038 U.S.A
Phone: 920-699-2000
Fax: 920-699-3683

MODEL NUMBER

SERIAL NUMBER

MODEL NUMBER: This number appears on sales literature, technical manuals and price lists.

SERIAL NUMBER: This number appears only on your mower. It contains the model number followed consecutively by the serial number. Use this number when ordering parts or seeking warranty information.

* Serial Plate located on cross member of frame under seat.

FastCat Pro

PREPARING FOR SAFE OPERATION

Operator preparation and training

Read the Operation & Safety Manual



- If an operator or mechanic cannot read English, it is the owner's responsibility to explain this material to them. If any portion of this material is unclear, contact your factory representative for clarification.
- Become familiar with the safe operation of the equipment, operator controls and safety signs. Know how to stop the engine and attachments quickly in an emergency. Do not operate or allow another person to operate this machine if there are any questions about safety.
- All operators and mechanics should be trained. The owner is responsible for training the users.
- Wear appropriate clothing, including long trousers and safety goggles or safety glasses with side shields when operating mower. Do not operate barefoot or wearing open sandals. Long hair, loose clothing or jewelry may get tangled in moving parts.
- Wear hearing protection.
- Never allow underage children, unskilled or improperly trained people operate this equipment. Local regulations can restrict the age of the operator.
- Data indicates that those operators age 60 years and above are involved in a large percentage of riding mower-related injuries. Those operators should evaluate their ability to operate the riding mower safely enough to protect themselves and others from injury.
- Do not carry passengers, especially small children. They may fall off and be seriously injured.
- Keep warning labels and this operator's manual legible and intact. Replacement labels and manuals are available from the factory.
- Do not operate machine while under the influence of drugs or alcohol.
- The owner/user can prevent and is responsible for accidents or injuries occurring to themselves, other people or property.



Site preparation and circumstances

- Evaluate the terrain to determine what accessories and attachments are needed to properly and safely perform the job. Only use accessories and attachments approved by the manufacturer.
- Clear the area to be mowed of objects such as rocks, toys, wire or other debris that may be picked up or thrown by the mower.
- Be sure the area is clear of pets and people, especially young children. Never assume they will remain where you last saw them. Stop the machine if any enter the area.
- Mow only in daylight or in good artificial light.
- Do not mow wet grass as tires may lose traction.

Machine preparation

- Check operator presence interlock system and brake operation. Adjust or repair any problems before using.
- Do not tamper with or defeat safety devices. Keep guards, shields and interlock safety devices in place and in proper working condition. They are for your protection.
- Keep all fasteners such as nuts, bolts and pins well secured.
- Visually inspect blades, blade bolts and the cutter assembly for wear or damage. Replace worn or damaged blades and bolts to preserve balance.
- Verify that machine and attachments, if any, are in good operating condition.
- Do not engage blades until ready to mow.

OPERATING SAFELY

In general

- Use extra care when loading or unloading the machine into a trailer or truck.
- Slow down and use caution when making turns and crossing roads and sidewalks. Stop blades if not mowing.
- Do not run the engine in an enclosed area where dangerous carbon monoxide fumes can collect.
- Do not place your foot on the ground while operating the machine.
- Before operating, lower the discharge chute, install the mulcher or put the entire grass catcher in place.
- Keep clear of the discharge opening at all times. Never direct the discharge toward a bystander. Stop operation if someone approaches.
- Keep washout ports and other mower housing service openings closed when mowing.
- Use care when pulling loads or using heavy equipment.
 - Use only approved drawbar hitch points.
 - Limit loads to those you can safely control.
 - Do not turn sharply. Use care when reversing.
 - Use counterweight(s) or wheel weights when suggested in the operator's manual.
- Never leave a machine unattended. Always turn off blades, set parking brake, stop engine and remove key before dismounting.

FastCat Pro

Starting

- Start only according to instructions in this manual or on the machine.
- Before attempting to start the engine, make sure:
 - the parking brake is on;
 - the PTO is disengaged;
 - the traction drive is in NEUTRAL.
- When starting the engine, make sure hands and feet are clear of the blades.
- Do not start the machine while standing in front of the discharge chute or with the chute directed at someone.
- Do not engage PTO at full throttle. Throttle to idle or lowest possible engine speed.
- Do not change engine governor settings or overspeed the engine. Operating the engine at excessive speed can increase the hazard of personal injury.

Interrupting operation

- Before leaving the operator's position:
 - Park on level ground.
 - Disengage the PTO.
 - Set the parking brake.
 - Shut off the engine and remove the key.
- Disengage the PTO and wait until the blades quit rotating:
 - before raising cutterdeck;
 - when not mowing;
 - for transport;
 - when crossing surfaces other than grass.
- Stop the engine, disengage the PTO, set parking brake and wait until the blades quit rotating and lower cutting unit:
 - before refueling;
 - before removing grass catcher;
 - before making height adjustment unless the adjustment can be made from the operator's position.
- Stop the engine, disengage the PTO, set parking brake and disconnect the spark plug wire(s) or remove the key:
 - before clearing blockages or unclogging chute;
 - before checking, cleaning or working on the machine;
 - after striking a foreign object. Inspect the machine for damage and make repairs before restarting;
 - if the machine begins to vibrate abnormally: shut off machine immediately. Inspect and make repairs as needed before restarting;
 - except for repairs or adjustments as specifically noted, such as for carburetor adjustment, where the engine must be running. Keep hands and feet clear of moving parts in these circumstances.
- Allow the blades to come to a complete stop when stopping operation to clear blockages, unclog, inspect the machine, do maintenance or repair.
- Reduce the throttle setting during engine shut-down and, if the engine is provided with a shut-off valve, turn the fuel off at the conclusion of mowing.

MANEUVERING SAFELY

In general

- Slow down before turning.
- Do not mow in reverse unless absolutely necessary. Always look behind and down for small children and pets before and during backing.
- Be aware when approaching blind corners, shrubs, trees, tall grass or other objects that may obscure vision.
- If tires lose traction, disengage the blades. If on a slope, head downhill.

Mowing slopes

Slopes are a major factor in loss-of-control and tip over accidents that sometimes lead to severe injury or death. All slopes require extra caution.



- Do not mow on slopes if uneasy or uncertain. Ultimate responsibility for safe operation on slopes rests with the operator.
- Do not mow excessively steep slopes.
- On zero turn machines, mow across slopes, not up and down.
- Avoid starting or stopping on a slope. If tires lose traction, disengage the blades and proceed slowly straight down the slope.
- With a zero turn machine, if tires lose traction going down a slope, steering control may be regained by speeding up.
- Mid-mount zero turns (belly mounted deck) have much greater traction pointed up slope than down slope. Be aware that traction may be lost going down a slope. Do not operate a mid-mount zero turn on slopes it cannot back up.
- Keep all movement on the slopes slow and gradual. Do not make sudden changes in speed or direction.
- Do not turn on slopes unless necessary, and then turn slowly and downhill when possible.
- Stay away from slopes if the ground is loose or if caught in the rain during mowing.
- Use lower speeds on a slope to avoid stopping or shifting.

- Use extra care with grass catchers or other attachments. These can change the stability of the machine.
- Remove obstacles such as rocks, tree limbs etc.
- Avoid driving over obstacles such as ruts, holes, rocks and roots whenever possible. Be alert to dips and rises. Uneven terrain can overturn a mower or cause it to slide. Tall grasses can hide obstacles.
- Do not mow drop-offs, ditches or embankments. The machine could suddenly turn over if a wheel runs over the edge or an edge caves in.
- Follow the manufacturer's recommendations for wheel weights or counterweights to improve stability.
- Do not mow slopes when grass is wet. Reduced traction could cause sliding.

FastCat Pro

MAINTENANCE SAFETY

In general

- Maintain machine according to manufacturer's schedule and instructions for maximum safety and best mowing results.
- Park machine on level ground.
- Never allow untrained personnel to service machine.
- Adjust or repair only after the engine has been stopped and the blades have quit rotating.
- Inspect grass catcher components regularly. If worn, damaged or deteriorated, they may expose moving parts or allow objects to be thrown.
- Replace parts if worn, damaged or faulty. For best results, always replace with parts recommended by the manufacturer.
- Disconnect battery or remove spark plug wire(s) before making any repairs. Disconnect the negative terminal first and the positive last. Reconnect positive first and negative last.
- Do not dismantle the machine without releasing or restraining forces which may cause parts to move suddenly.
- Provide adequate support, e.g. jack stands for lifted machine or parts if working beneath.
- Do not put hands or feet near or under rotating parts.
- Clean up spilled oil or fuel thoroughly.
- Replace faulty mufflers.
- To reduce fire hazards, keep the engine, muffler, battery compartment and fuel storage area free of grass, leaves, debris buildup or grease.
- Hydraulic fluid can penetrate skin, use paper to check for leaks. Relieve hydraulic pressure before disconnecting hoses. Make sure connections are tight and hoses are in good condition.

Blades

- Mower blades are sharp and can cut. Use extra caution when handling. Remove obstructions with care. Wrap the blade(s) or wear gloves.
- Be aware that rotating one blade on multi blade mowers can cause other blades to rotate.
- Only replace blades. Never straighten or weld them.
- Keep other persons away from blades.



Fuel

- Gasoline and diesel fuels are flammable; gasoline vapors are explosive. Use extra care when handling.
- Store only in containers specifically designed for fuel.
- When refueling or checking fuel level:
 - Stop the engine and allow to cool;
 - Do not smoke;
 - Refuel outdoors only;
 - Use a funnel;
 - Do not overfill;
 - If fuel is spilled, do not attempt to start the engine until the spill is cleaned up and vapors have cleared.



Sparks from static electricity can start fires or cause explosions. Flowing fuel can generate static electricity. To prevent static electricity sparks:

- Keep containers electrically grounded. Do not fill containers in a vehicle or on a truck or trailer bed with a plastic liner. Fill containers on the ground away from the vehicle.
- When practical, remove gas powered equipment from the truck or trailer and refuel it on the ground. If equipment must be refueled on the truck or trailer, refuel from a portable container rather than a dispenser nozzle.
- Keep the dispenser nozzle in contact with the rim of the fuel tank or container opening until fueling is complete. Do not use a nozzle lock-open device.
- Replace caps on fuel cans and tanks securely.

BATTERY

Battery acid is caustic and fumes are explosive and can cause serious injury or death.

To reduce the risk of personal injury when working near a battery:

- When working with battery acid, use protective equipment such as, but not limited to, goggles, face shield, rubber gloves and apron.
- Avoid leaning over a battery.
- Do not expose a battery to open flames or sparks.
- Be sure batteries with filler caps are properly filled with fluid.
- Do not allow battery acid to contact eyes or skin. Flush any contacted area with water immediately and get medical help.
- Charge batteries in an open, well ventilated area, away from sparks and flames. Unplug charger before connecting or disconnecting from battery.

WARNING

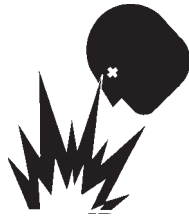

STORAGE AND TRANSPORTATION

- Stop the engine and allow to cool before storing.
- Drain the fuel tank outdoors only.
- Store fuel in an approved container in a cool, dry place.
- Keep the machine and fuel containers in a locked storage place to prevent tampering and to keep children from playing with them.
- When the machine is to be parked, stored or left unattended, lower the cutterdeck unless a positive mechanical lock is used.
- Do not store the machine or fuel container near heating appliances with an open flame such as a water heater or an appliance with a pilot light.
- Keep gasoline storage area free of grass, leaves and excessive grease to reduce fire hazard.
- Clean grass and debris from cutting units, drives, mufflers and engine to help prevent fires.

JUMP STARTING

1. Be sure the jumper cables are in good condition. Turn off the ignition and all electrical accessories on both machines.
2. Position the machine with a good (charged) battery next to but not touching the machine with the dead battery so jumper cables will reach.
3. When making cable connections:
 - make sure the clamps do not touch anywhere except to intended metal parts,
 - Never connect a positive ("+" or red) terminal to a negative ("- " or black) terminal.
 - Make sure the cables won't get caught in any parts after the engines are started.
4. Connect one end of the first jumper cable to the **positive** terminal on one battery. Connect the other end to the **positive** terminal on the other battery.
5. Connect one end of the other cable to the **negative** terminal of the machine with a good (charged) battery. Make the final connection on the engine of the machine to be started, away from the battery.
6. Start the vehicle with the good battery, then the machine with the discharged battery.
7. Remove the cables in the exact reverse order of installation. When removing each clamp, take care it does not touch any other metal parts while the other end remains attached.

FastCat Pro

TOOLS REQUIRED FOR ASSEMBLY

- Wrecking bar
- Claw hammer
- Sockets: 1/2", 15/16
- Wrenches: 18mm, 1/2", 9/16", 3/4", 15/16"
- Tire pressure gauge

NOTE: All references below to the "right" or "left" are with respect to an operator at the controls.

1. UNCRATE UNIT

- Discard packing materials. Loosen the caster wheel axle bolts and bumper bolts to remove the shipping brackets.
Discard shipping brackets.
- Re-install and tighten bumper bolts.
- Tighten caster wheel axle bolts against caster axle spanner bushings to 80 ft/lbs.

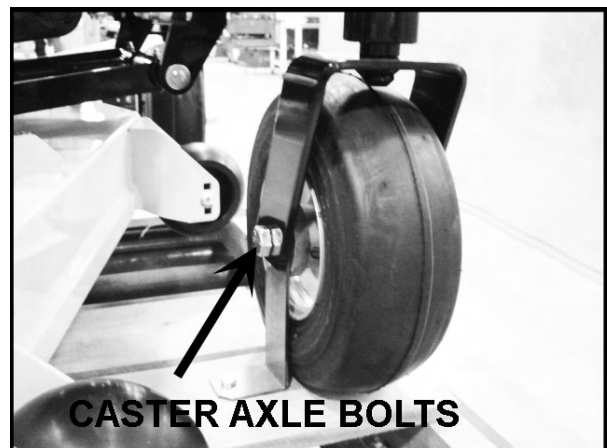
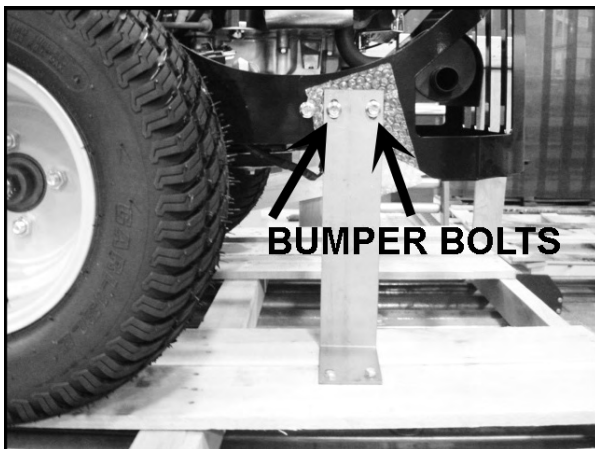

2. TIRE PRESSURE

- Set tire pressures to 14 lbs/in² (1.0 kg/cm²). Tires are overinflated for shipping.

3. TRACTION LEVERS

- Tighten bolt **A**.
- Sit on the machine. Levers **C** may be moved to upper set of holes in bar **B** for a better operator fit.

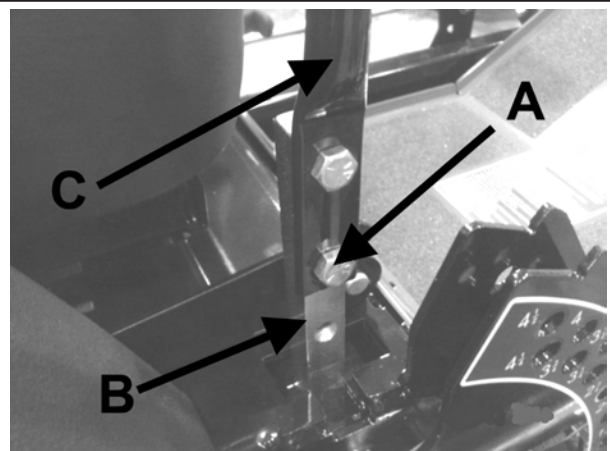

SETUP INSTRUCTIONS

FastCat Pro

4. FINAL PREPARATIONS

- Check the engine and hydraulic oil levels. Top off with the correct oil if necessary. Use 10W30 motor oil for the engine. Use fresh, clean 20W50 motor oil for the hydraulic system. See engine operation manual for specified motor oil viscosity.
- Charge battery and properly connect cables. See steps below.

⚠ WARNING

Battery acid is caustic. Fumes are explosive and can cause serious injury or death.

Use insulated tools, wear protective glasses or goggles and protective clothing when working with batteries. Read and obey the battery manufacturer's instructions.

Be certain the ignition switch is OFF and the key has been removed before servicing the battery.

- a) Verify battery polarity before connecting or disconnecting the battery cables.
 - b) When installing the battery, always assemble the RED, positive (+) battery cable first and the ground, BLACK, negative (-) cable last.
 - c) Tighten cables securely to battery terminals and apply a light coat of silicone dielectric grease to terminals and cable ends to prevent corrosion. Keep terminal covers in place.
- Read Operation and Safety Manual before starting. Operator Manual is located under the seat/footplate. Tilt seat forward / footplate up to access manual.



OR



- If deck does not cut level, see deck leveling procedure in the adjustments section of this manual.
- Run engine at full RPM for 5 minutes before engaging blades to allow the engine to be fully lubricated before load is applied.
- Check the hydro stat neutral adjustment. Neutral is set at the factory but may require readjustment. See adjustments section of this manual.
- Do not use the machine without an approved grass collector, the grass discharge chute or mulching plates correctly fitted.

FastCat Pro

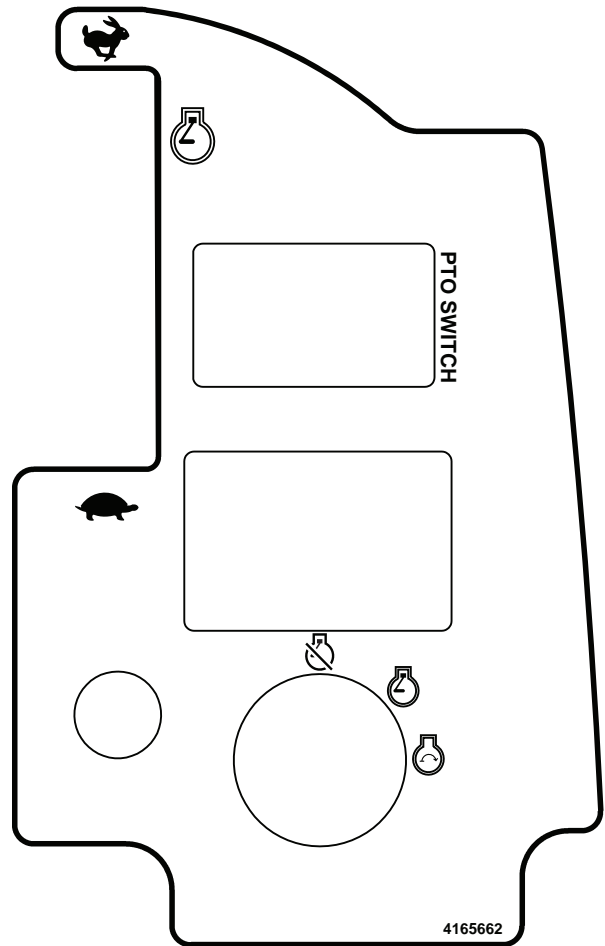
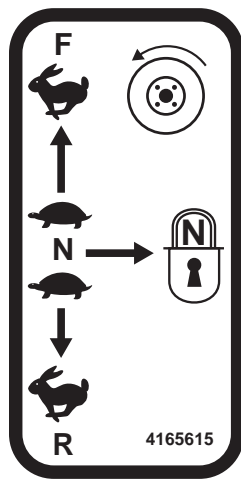
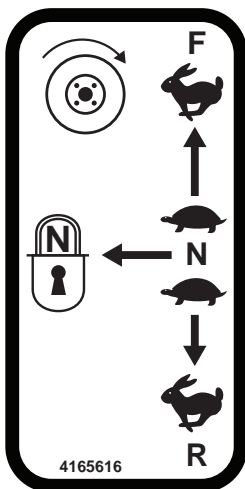

	<p>⚠ DANGER</p> <p>ROTATING BLADES</p> <ul style="list-style-type: none"> - KEEP HANDS AND FEET AWAY - STOP ENGINE AND LET BLADES STOP BEFORE REMOVING GRASS COLLECTOR OR UNCLOGGING.
	<p>⚠ WARNING</p> <p>THROWN OBJECTS</p> <ul style="list-style-type: none"> - KEEP AREA CLEAR OF PEOPLE AND PETS. - REMOVE OBJECTS BLADE MAY STRIKE AND THROW. - STOP BLADES TO CROSS GRAVEL AREAS. - DO NOT OPERATE WITHOUT CHUTE, MULCHER OR ENTIRE GRASS COLLECTOR IN PLACE. <p>4164269</p>

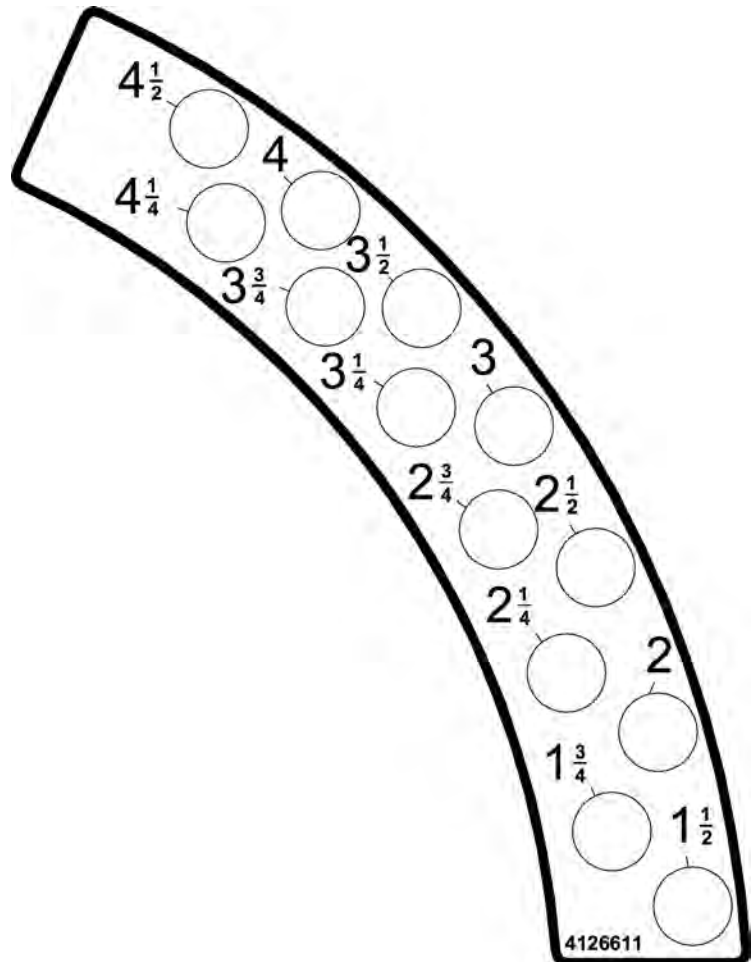
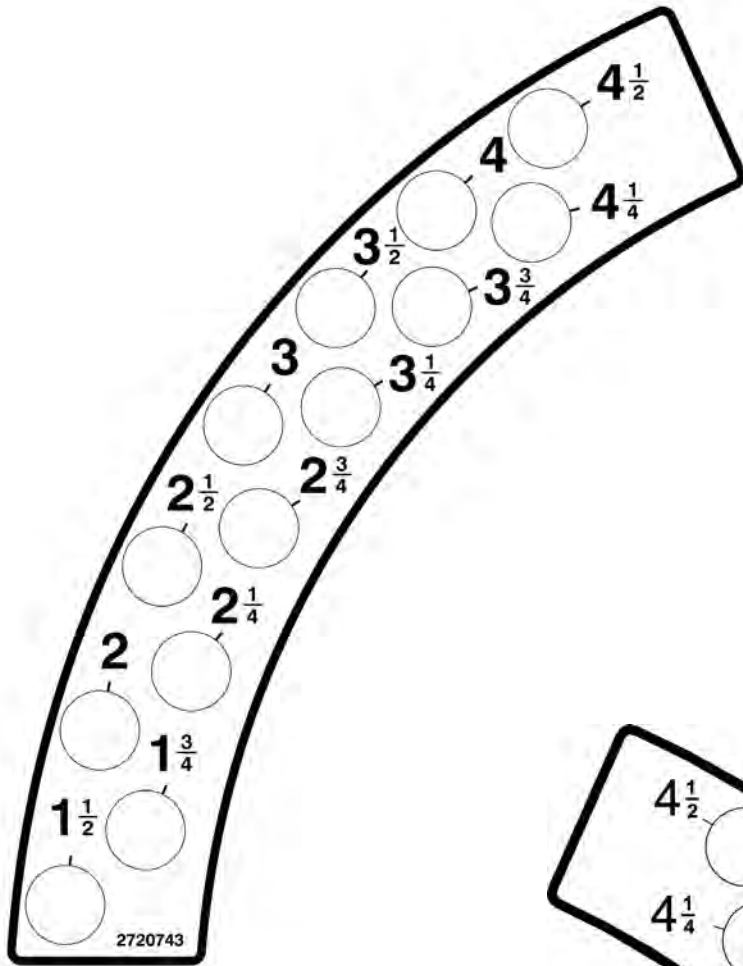

FastCat Pro

WARNING

BEFORE STARTING OR SERVICING:



Read and understand the Operator's Manual & labels.

- Be sure machine is in safe operating condition.
- Move traction levers to neutral lock, parking brake to ON.
- Set PTO switch to OFF.

BEFORE LEAVING SEAT:

- Move traction levers to neutral lock, parking brake to ON.
- Set PTO switch to OFF.
- Turn engine keyswitch to OFF.
- Remove key.

WARNING

AVOID SERIOUS INJURY OR DEATH:

- Read and obey the Operation & Safety Manual.
- Remove objects that could be thrown by the blades.
- Use caution on slopes. Stay off slopes the machine cannot back up.
- Stop blades and drive down slowly if machine slides or stops going on slope.
- Do not mow when children or others are around.
- Do not carry a child or passenger-even with blades off.
- Look down and behind before and while backing.
- Do not operate unless trained.
- Do not operate unless guards, shields and interlocks are in place and working.
- Replace labels and Operation and Safety Manual if lost or damaged.

WARNING

- Remove debris buildup. Debris under belt cover or near muffler can cause fires.
- Blades continue to rotate for a few seconds after blades are turned off.
- Blades must be at least 1/8" above bottom of housing.
- All blades must be identical. Check blade bolts daily for tightness.
- Inspect for damage after striking a foreign object. Make repairs before restarting operation.
- Find and repair cause of any abnormal vibration.

ADVERTENCIA

- Leer el manual del operador. No permitir que personas no capacitadas para ello usen la máquina.
- Mantener los protectores en su lugar y sus tornillos debidamente fijados.
- Antes de limpiar, ajustar o reparar este equipo, apagar todos los mandos, aplicar el freno de estacionamiento y apagar el motor.
- Mantener las manos, los pies y la ropa alejados de las piezas en movimiento.
- No conducir como pasajero ni llavar pasajeros en máquinas sin asiento para ello.
- Mantener a las demás personas alejadas durante el funcionamiento de la máquina.
- Si no sabe leer inglés, solicitarle a otra persona que le lea y explique el contenido de las etiquetas y del manual de la máquina.

4165610

DECAL IS LOCATED UNDER FOOTPLATE.

DECK DRIVE BELT ROUTING

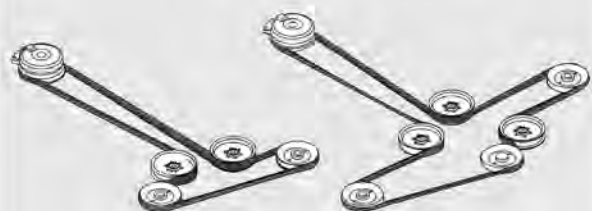

2 SPINDLE CONFIGURATION

3 SPINDLE CONFIGURATION



BLADE INSTALLATION

- BELLEVILLE WASHER MUST BE POSITIONED AS SHOWN.
- TORQUE BLADE BOLTS TO 70 FT-LBS.
- SEE OPERATOR'S MANUAL FOR DETAILED BLADE CHANGING PROCEDURE.

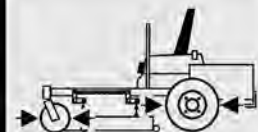

TIRE PRESSURE

14 PSI (1KG/CM²)

HEIGHT OF CUT

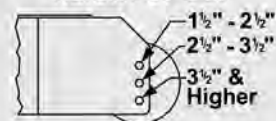

ANTI-SCALP ROLLER BRACKET BOLT LOCATION

4164525

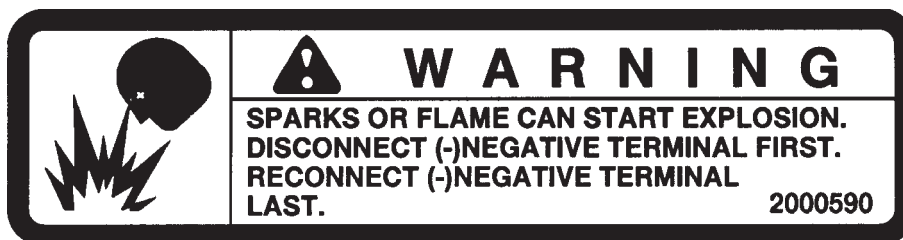
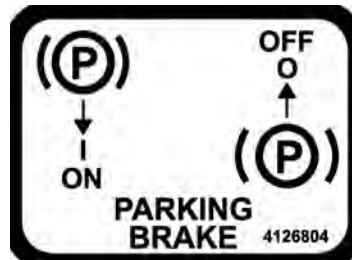
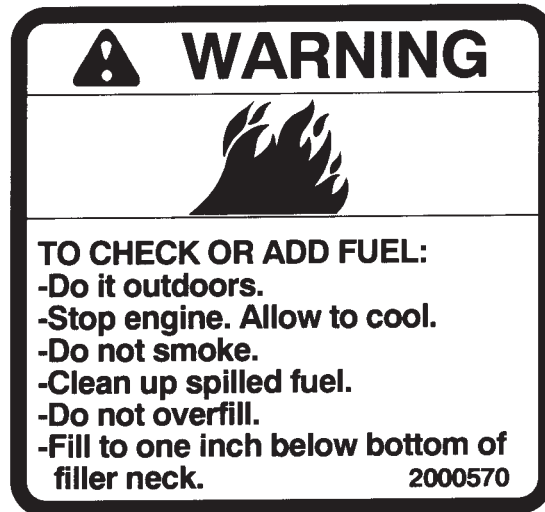

FastCat Pro

KEYSWITCH (K) - The keyswitch has three positions: **OFF**, **RUN**, and **START**. Insert the key and turn it clockwise to move the switch from **OFF** to **RUN**. Turn it further to **START** and hold to engage the starter. Release the key and the switch will return to **RUN** from **START**. Turn the key counterclockwise to **OFF** to stop the engine.

THROTTLE (T) - Move the throttle lever forward to increase engine speed until the maximum governed engine **RPM** is reached. Move the lever rearward to decrease engine speed until the engine reaches its idle speed.

CHOKE (C)

For Kawasaki Engines, pull the choke control out to set the choke **ON**. Push it in to set the choke **OFF**.

POWER TAKE OFF (PTO) SWITCH (P) -

The operator must be in the seat when engaging the **PTO** or the engine will kill. Pulling the **PTO** switch out engages (turns on) the **PTO** and starts the blades or other attachment. Pushing the **PTO** switch in disengages (turns off) the **PTO** and stops the blades or other attachment.

NOTE: The **PTO** switch does not control attachments powered by a separate engine.

- Disengage the **PTO** whenever you stop or leave the operator's position
- Shut off engine with the key and remove the spark plug wires before making adjustments or unplugging a clogged mower.
- Do not engage the **PTO** until ready to start mowing.

HOUR METER (M) - Records accumulated time the machine is in operation and provides service alerts. Push and release **MODE** button to toggle between functions. Provided service alerts include change engine oil and filter, change hydraulic oil, and service air filter. When the service time is approaching, an alert message will flash temporarily, interrupting whatever mode the meter is in. This will continue until the alert is reset. When the service interval reaches "0" hours, the word "NOW" replaces the hours remaining. To reset the service alert, depress and hold down the mode button for 6 seconds while in the alert to be cleared.

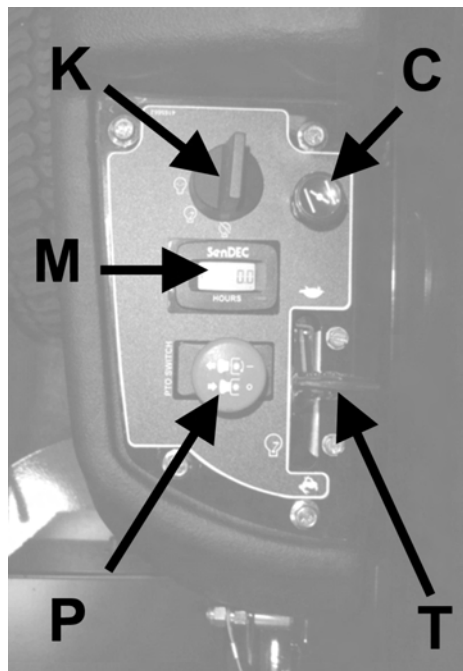

At operator's right side

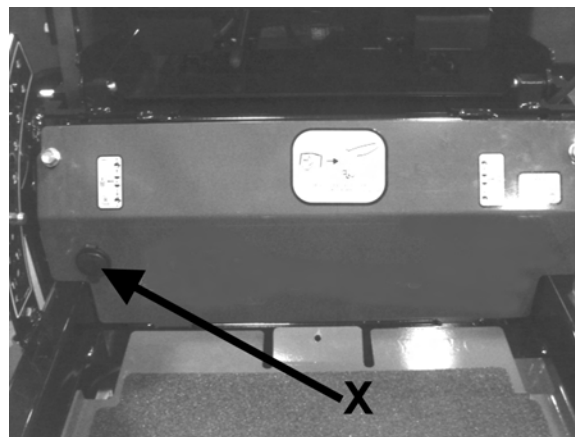

Below seat

12 VOLT POWER OUTLET (X) - A 12 volt power outlet is provided to operate 12 volt personal accessories.

FUEL SELECTOR VALVE (U)

The fuel tank selector valve is located behind the seat.

The fuel tank selector valve has three positions:

Off: The tank selector is off when the lever points down. The selector should be off whenever the machine is transported or stands unused for any length of time. Shutting off the fuel supply avoids the possibility of flooding should any dirt get under the carburetor float needle. Leaving the tank selector in either tank position can allow severe flooding, which may ruin the engine by diluting the oil.

Right Tank: Fuel flows from the right tank when the selector is turned 1/4 turn toward the right.

Left Tank: Fuel flows from the left tank when the selector is turned 1/4 turn toward the left.

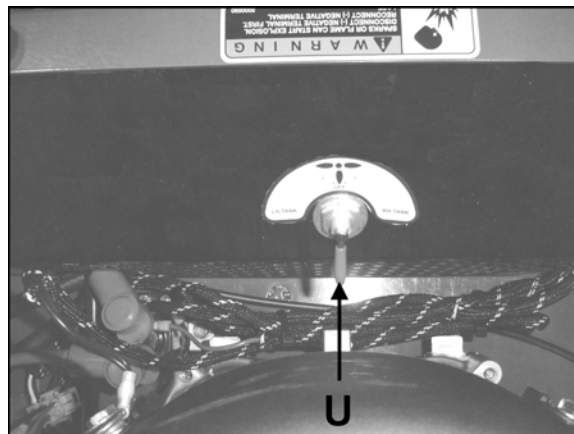

FastCat Pro

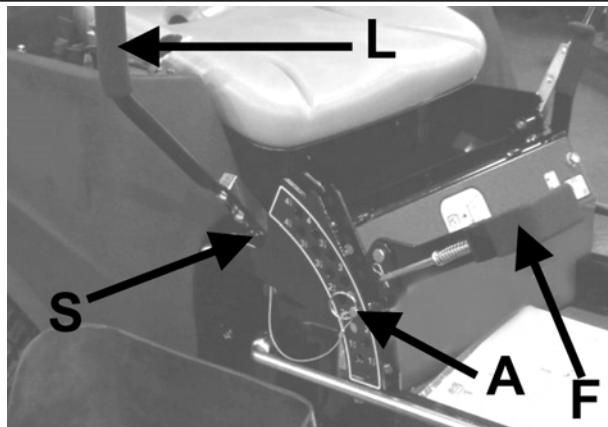

**Lift and traction levers
(operator's right side)**

LIFT LEVER (F) - Used to raise the cutterdeck to maximum height for transport, curb climbing or blade changing. To return to preset height of cut, lower lift lever until it contacts height of cut pin **A**.

TRACTION LEVERS (L) - Each of the two traction levers controls the drive wheel located on the same side. They control the forward and reverse movement of the machine, provide steering and also provide dynamic braking.

The operator must be in the seat and the parking brake must be **OFF** to engage the traction drive. To engage traction drive, move the traction levers toward the center of the machine until they are out of neutral lock slot **S**.

Forward movement - To move the machine straight ahead, push both traction levers forward equally from their neutral position. Forward speed increases as the levers are moved farther forward from the neutral position. Maximum forward speed is reached when the levers hit the front of the forward-reverse slot. When traveling forward, pulling the traction levers rearward slows the machine. The machine stops when the neutral position is reached.

Reverse movement - To move the machine straight back, pull both traction levers back equally from their neutral position. Reverse speed increases as the levers are moved back farther. Maximum reverse speed is reached when the levers hit the rear of the forward-reverse slot. When moving in reverse, pushing the levers forward slows the machine, and the machine stops when the neutral position is reached.

NOTE: Reverse is spring loaded to return to neutral. This spring resistance may be felt when moving the traction levers into reverse. When the levers are released in reverse, spring tension will slowly return them to the neutral position.

STEERING - To steer, move one lever forward and one back.

Turns during forward movement:

- **Right turn** - move the right traction lever back toward neutral to slow the right drive wheel.
- **Left turn** - move the left traction lever back toward neutral to slow the left drive wheel.

Turns during reverse movement:

- **Reverse right turn** - move the right traction lever forward toward neutral to slow the right drive wheel.
- **Reverse left turn** - move the left traction lever forward toward neutral to slow the left drive wheel.

Slow, sweeping turns are made with both traction levers on the same side of neutral and slightly apart. True zero radius turns about the center of the machine are made by having one lever in reverse while the other is in forward. By varying the relative positions of the two levers, the rate of turn is varied to suit the mowing situation.

CAUTION

Slow down before making sharp turns. The machine is capable of turning very rapidly when the levers are moved further apart from each other. Loss of control and/or turf damage may result.

PARKING BRAKE (R) - Pull the parking brake lever up and back to put the parking brake ON. Push it forward and down to put the parking brake OFF.

The parking brake must be ON to start the engine. It must also be ON to keep the engine running if the operator leaves the seat. The parking brake must be OFF to keep the engine running when a traction lever is moved out of neutral lock.

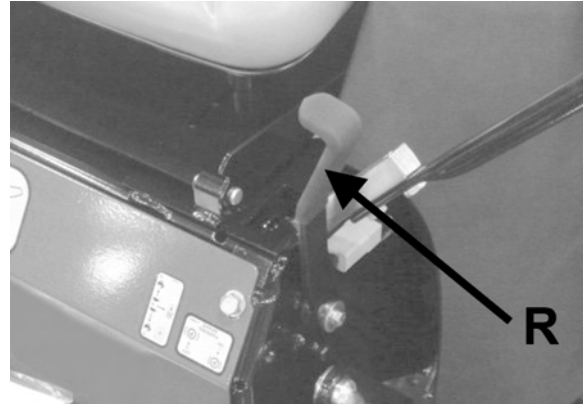

Parking brake in ON position
(operator's left side)

PUSHING THE MACHINE

The machine may be pushed with the engine off, the parking brake off, and the bypass valves open.

To open the bypass valves, move the parking brake to the OFF position, then lift and pull bypass control rod C through the large opening D, until the control rod stop is past the opening. Drop rod C into the small opening to lock in place. Repeat for the other bypass control rod.

To close the bypass valves, lift bypass control rod C allowing the control rod stop to retract through the large opening D.

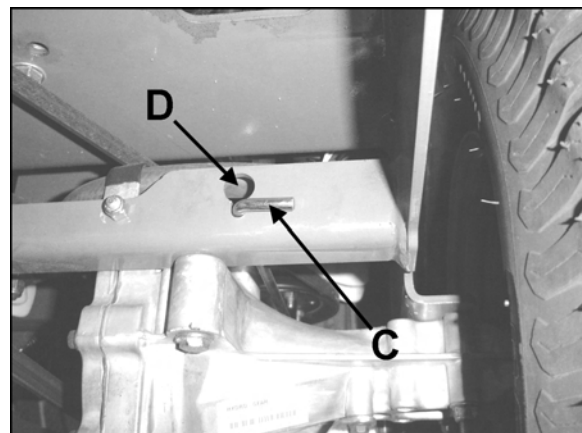
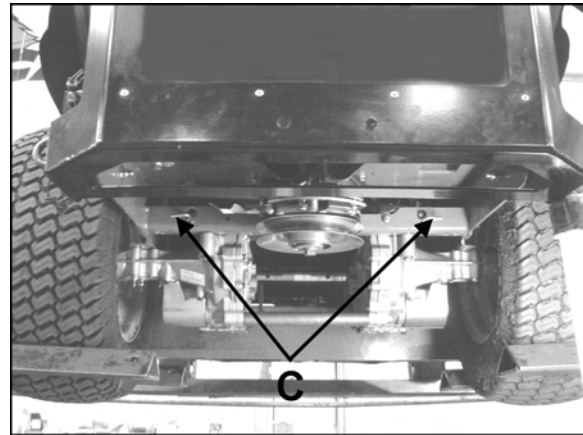

FastCat Pro

**PRE-OPERATION CHECK LIST
(OPERATOR'S RESPONSIBILITY)**

- | | |
|---|---|
| <ul style="list-style-type: none">___ Review and follow all safety rules and safety decal instructions.___ Check that all safety decals are installed and in good condition. Replace if damaged.___ Check to make sure all shields and guards are properly installed and in good condition. Be sure that either the discharge shield or complete vacuum attachment is installed.___ Check that all hardware is properly installed and secured.___ Check that equipment is properly and securely attached to power unit.___ Check to be sure engine is free of dirt and debris. Pay particular attention to the cooling fins, governor parts and muffler. Clean air intake screen. Check air cleaner; service if necessary. | <ul style="list-style-type: none">___ Never allow riders.___ Inspect area and remove stones, branches or other hard objects that might be thrown, causing injury or damage.___ Clean area around oil fill dipstick. Remove dipstick and check to be sure oil is in operating range (between marks on dipstick). Add oil if necessary but Do Not Overfill. Install dipstick assembly firmly until cap bottoms out on tube. Dipstick assembly must always be secured into fill tube when engine is running.___ Check all lubrication points and grease as instructed in manual.___ Check hydrostatic fluid level. Check to be sure cooling fins on hydro stat are clean.___ Perform a functional check of the safety interlock system each time you operate the unit. |
|---|---|

FUELING

- Fill fuel tank with good quality, clean, unleaded regular gasoline. Do not use hi-test fuel.
- Use a funnel to avoid spilling.

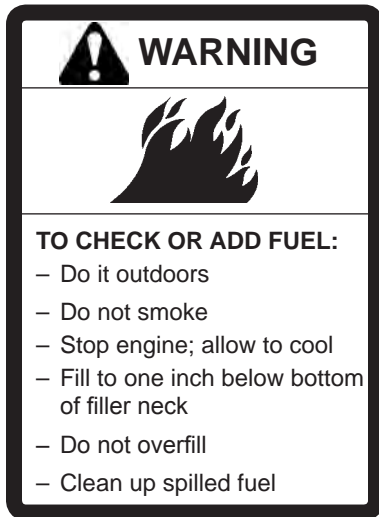

BEFORE STARTING THE ENGINE

- Be familiar with all controls, how each functions and what each operates.
- Check the engine oil level and add if necessary. Using the fuel selector valve, select which tank will supply fuel
- **Choke:** For cold starts, set the throttle lever to the half-open position and pull the choke out to the ON position. For warm starts set the throttle to the half-open position and the choke to the OFF position.

OPERATOR PRESENCE INTERLOCK SYSTEM

To start the engine:

- The PTO switch must be **OFF**.
- Both traction levers must be in the neutral lock position.
- The parking brake must be **ON**.

To operate the machine:

1. The operator must be in the seat or engaging the PTO will kill the engine.
2. The parking brake must be **OFF** and the operator must be in the seat, or moving a traction lever from the neutral lock position will kill the engine.

STARTING THE ENGINE

1. Turn the key to operate the electric starter to start the engine. Release the key when the engine starts.
2. If the engine does not start immediately, do not crank for more than 10 seconds at a time. Allow 60 seconds for the starter motor to cool down between starting attempts to prevent the starter motor from burning out.
3. If the choke is ON when the engine starts, gradually back it off until the engine runs with no choke at all.

OPERATING NOTES

- Practice at slow engine and travel speeds with the PTO off until fully familiar with the controls.
- For normal cutting the throttle should be set at the full open position. By using the traction levers to speed up or slow down the machine during use, maximum control and cutting efficiency can be maintained.
- Using the machine at less than full throttle in heavy conditions will cause the engine to labor and result in excessive wear and can cause damage to the transaxles.

DRIVING

1. With the PTO disengaged, move the parking brake to OFF.
2. Move both traction levers out of neutral lock.
3. Push both traction levers forward evenly to drive forward in a straight line. Pull both traction levers back evenly to drive backward in a straight line.
4. **Steering** - Move one lever forward and one back.

Turns during forward movement:

- **Right turn** - move the right traction lever back toward neutral to slow the right drive wheel.
- **Left turn** - move the left traction lever back toward neutral to slow the left drive wheel.

Turns during reverse movement:

- **Reverse right turn** - move the right traction lever forward toward neutral to slow the right drive wheel.
- **Reverse left turn** - move the left traction lever forward toward neutral to slow the left drive wheel.

 CAUTION

Use caution when making turns. Slow down before making sharp turns to help maintain control and to prevent torn turf from skidding or spinning tires. To help prevent turf damage, keep both drive tires moving whenever a turn is made.



TIP: The best way to make a sharp "zero" turn is to come to a stop, get the machine moving in reverse with both drive wheels and then power the machine around with the outside wheel. This technique keeps the drive tires turning and results in less turf damage.



CUTTING

1. Place the discharge chute in the down position or correctly fit a grass collector or mulcher plate.
2. Sit in the seat.
3. Start the engine.
4. Turn the blades on by pulling up on the PTO switch. Do not start the blades at full throttle. Instead, use the slowest throttle setting that will allow the engine to pick up the blade load to reduce the wear on the belts and electric clutch.
5. After the blades are rotating, set the throttle to maximum. Use the traction levers to obtain the required cutting speed, to steer around obstacles and to turn at the end of a cut.

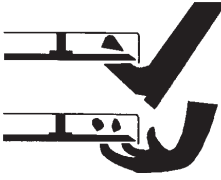
CUTTING TIPS

- When mowing large areas, start by turning to the right so that clippings will be discharged away from shrubs, fences, driveways, etc. After two or three rounds, mow in the opposite direction, left hand turns, until finished.
- If grass is extremely tall, it should be mowed twice, the first cut relatively high, the second cut to the desired height.
- Use the left side of the mower for trimming.
- Choose cutting directions so that clippings are thrown onto areas that already have been cut. This method results in the most even distribution of clippings and more uniform, better appearing cuts.
- Use a different mowing pattern each time where possible. This helps prevent rutting and leads to a more uniform cut by keeping the grass from always laying the same way.

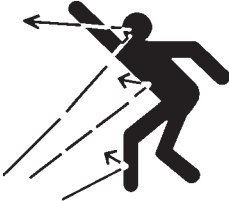
	 DANGER
	ROTATING BLADES <ul style="list-style-type: none">- KEEP HANDS AND FEET AWAY.- STOP ENGINE AND LET BLADES STOP BEFORE REMOVING GRASS COLLECTOR OR UNCLOGGING.

	 WARNING
	THROWN OBJECTS <ul style="list-style-type: none">- KEEP AREA CLEAR OF PEOPLE AND PETS.- REMOVE OBJECTS BLADE MAY STRIKE AND THROW.- STOP BLADES TO CROSS GRAVEL AREAS- DO NOT OPERATE WITHOUT CHUTE, MULCHER OR ENTIRE GRASS CATCHER IN PLACE.

MAINTENANCE OPERATION	Maintenance is an ongoing job. These intervals are maximum times between maintenance operations. Perform more often under severe conditions.						
	FIRST 5 HOURS	BEFORE EACH USE	EVERY 25 HOURS	EVERY 50 HOURS	EVERY 100 HOURS	EVERY 200 HOURS	YEARLY
ENGINE							
Consult the engine manual for additional information and instructions							
Check/Top Up Oil Level		X					
Check For Leaks		X					
Clean Air Intake Screen		X					
Clean Air Cleaner Precleaner			X				
Clean Air Cleaner Element			X				
Clean Cooling Fins					X		
Change Oil And Filter	X	See engine manufacturer's manual					
Check/Replace Spark Plugs						X	
TRANSAXLE							
Check Oil Level		X					
Check For Leaks		X					
Change Oil And Filter						X	
MACHINE							
Check Interlock Operation		X					
Check Tire Pressures		X					
Check/Top Up Battery							X
Lubricate All Points		X					

MAINTENANCE RECORD

FastCat Pro

NOTES

GENERAL	DATE	HRS	DATE	HRS	DATE	HRS	DATE	HRS	DATE	HRS	DATE	HRS
Check Tire Pressures												
Lubricate All Points												
Check Nuts & Bolts												
ENGINE												
Check Oil Level												
Change Oil												
Clean Air Cleaner Element												
Clean Cooling Fins												
Replace Air Cleaner Element												
Clean & Gap Spark Plugs												
TRANSAXLE												
Change Oil And Filter												
NOTE: After first 5 hours of operation change engine oil and filter.												

FastCat Pro

CHECK DAILY

Operator Presence Interlock System - Start Operation

For the engine to crank, the parking brake must be on, the PTO (blades) off and traction levers in the neutral lock position. Sit in the seat and check, one by one, if the engine will crank with the parking brake off, the blades on, and either traction lever out of neutral lock.

Operator Presence Interlock System - Run Operation

The operator must be in the seat for the engine to run with the parking brake off, the traction levers moved out of the neutral lock position, or the blades on. To check:

1. Start the engine and run at 1/2 throttle with the operator on the machine but raised off the seat.
2. One by one: move the parking brake to the OFF position, traction levers out of the neutral lock position (check each independently), and turn the blades on. Each check should kill the engine after 1/2 second. (A 1/2 second delay is built into the system to prevent engine cutout when traversing rough terrain.)

Repair machine before using if the Operator Presence Interlock System does not operate correctly in start or run. Contact your authorized Schiller Grounds Care, Inc. dealer.

Hardware

Tighten any nuts and bolts found loose. Replace any broken or missing cotter pins. Repair any other problems before operating.

Tire pressure

Tires should be kept inflated to 14 lbs/in² (1.0 kg/cm²). Improper tire inflation can cause rapid tire wear and poor traction. Uneven inflation can cause uneven cutting. Overinflation of caster tires can cause casters to "wobble" on hard surfaces.

BATTERY

⚠ WARNING Battery acid is caustic and fumes are explosive and can cause serious injury or death.

Use insulated tools, wear protective glasses or goggles and protective clothing when working with batteries. Read and obey the battery manufacturer's instructions.

Be certain the ignition switch is OFF and the key has been removed before servicing the battery.

1. Verify battery polarity before connecting or disconnecting the battery cables.
2. When installing the battery, always assemble the RED, positive (+) battery cable first and the BLACK ground, negative (-) cable last.
3. When removing the battery, always remove the BLACK ground, negative (-) cable first and the red, positive (+) cable last.

4. Check the electrolyte level every 100 hours of operation or yearly, whichever comes first. Top off with distilled water if necessary.

NOTE: Sealed batteries cannot be checked or topped off.

5. Clean the cable ends and battery posts with steel wool. Use a solution of baking soda and water to clean the battery. Do not allow the solution to enter into the battery cells.
6. Tighten cables securely to battery terminals and apply a light coat of silicone dielectric grease to terminals and cable ends to prevent corrosion. Keep terminal covers in place.

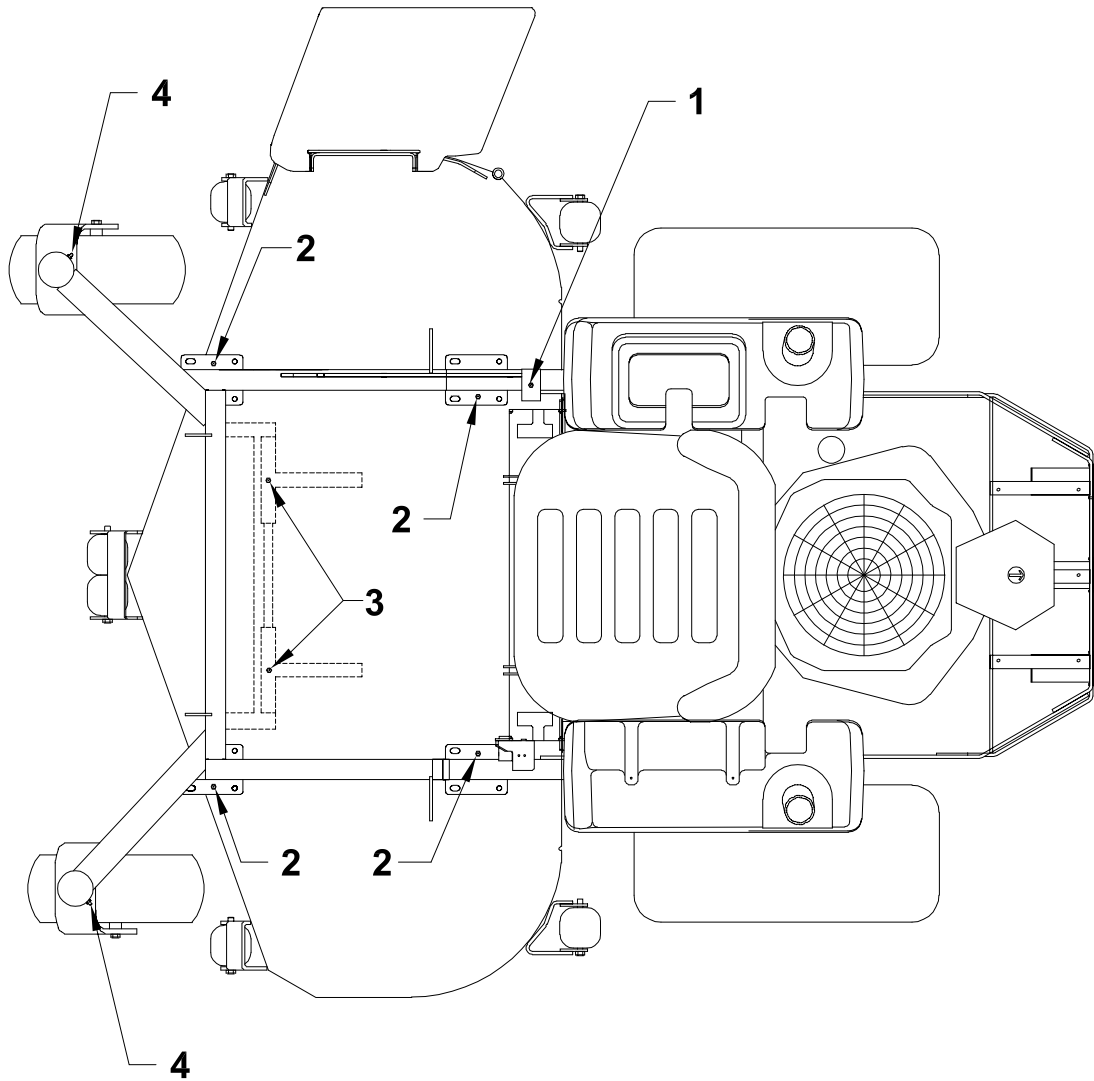

LUBRICATION

Every 50 hours of operation, lubricate the following points (1-3) with grease:

1. Deck lift lever (1 point)
2. Deck lift pivots (4 points)
3. Pull arms (2 points located at the front of the cutterdeck)
4. Caster wheel pivots (2 points)
(Lubricate every 500 hours or once a year)

NOTE ON BLADE SPINDLES - The blade spindles on these machines use a superior sealed bearing that does not require relubrication.

FastCat Pro

ENGINE OIL

Do not perform engine maintenance without the engine off, spark plug wires disconnected and PTO disengaged.

AFTER FIRST FIVE (5) HOURS

While the engine is warm:

1. Release the oil drain hose assembly from the engine clip **J**. Lay hose assembly over the frame edge or through the frame cutout, which ever is most convenient.
2. Remove the rubber cap **D** from the tip of the hose assembly and turn the drain valve to allow oil to drain from the engine. Dispose of used oil in accordance with local requirements.
3. Clean drain valve and tighten the plastic portion of the drain valve back into the metal portion of the valve. Replace rubber cap over the tip of the valve. Replace hose assembly back into engine clip.
4. Change oil filter.
5. Fill the crankcase with fresh oil to the full mark. Do not overfill. See engine manual for oil specifications.

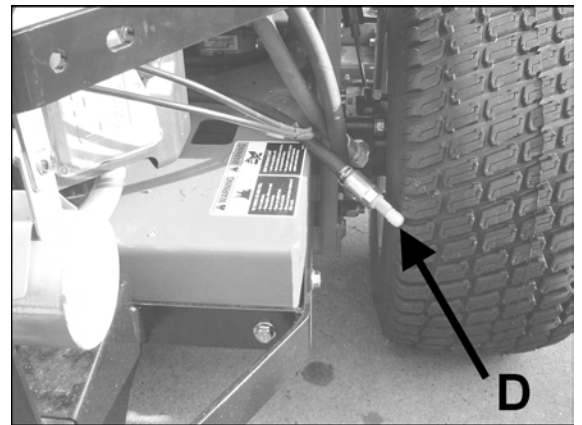
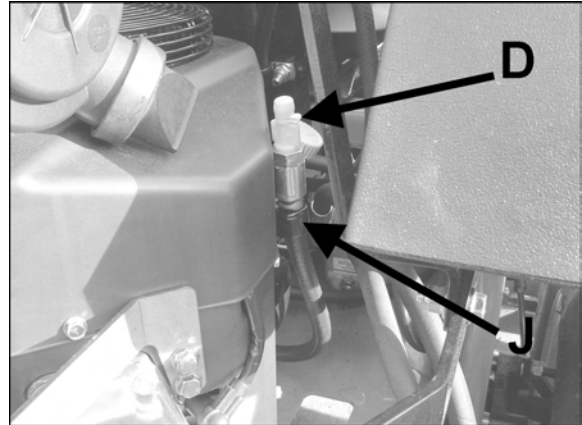

DAILY

1. Check oil level with the dipstick.
2. If oil is needed, add fresh oil of proper viscosity and grade. See engine manual for oil specifications. Do not overfill.
3. Replace dipstick before starting engine.

PERIODIC OIL CHANGES

1. See engine manual for oil and filter change intervals after the break-in period.
2. Follow instructions for first oil change, above.

SPARK PLUGS

Remove each plug and check condition.

- Good operating conditions are indicated if the plug has a light coating of grey or tan deposit.
- A white blistered coating indicates overheating. A black coating indicates an "over rich" fuel mixture. Both may be caused by a clogged air cleaner or improper carburetor adjustment.
- Do not sandblast, wire brush or otherwise attempt to repair a plug in poor condition. Best results are obtained with a new plug.
- Set plug gap as specified in engine manual..

FUEL FILTER

An in-line fuel filter is located in the fuel supply line. Inspect at every oil change to make sure it is clean and unobstructed. Replace if dirty.

AIR CLEANER

Clean and replace the air cleaner element as specified in the service chart. Uneven running, lack of power or black exhaust may indicate a dirty air cleaner.

1. Unclamp end cover **C** and remove existing cleaner element **A**.
2. Insert new element **A** and replace cover **C**. Ensure breathing port **B** is pointing down and towards the front of the tractor.

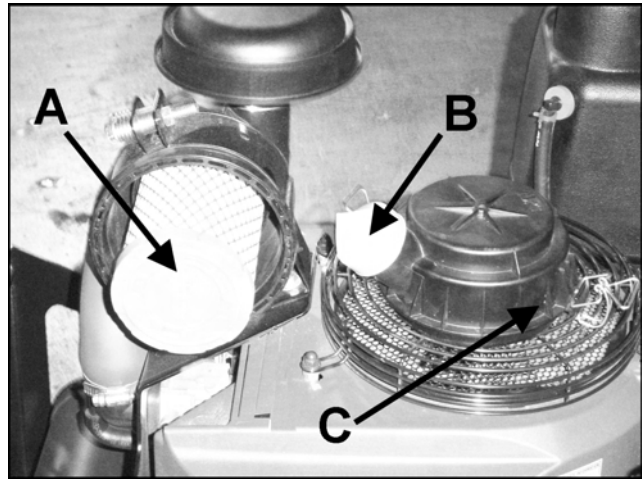

CLEANING MACHINE

Clean the machine after use. The machine will run cooler and last longer if kept free of clippings and other debris. A clean machine also reduces the risk of fire due to accumulation of combustible debris and chaff

Brush or blow clippings and debris off the cutterdeck and engine deck.

WASHING MACHINE

CAUTION: Improperly washing a machine can cause water to enter bearings and other components. This can greatly reduce component life.

- Do not use a pressure washer. Do not direct water at bearings or seals. High pressure water can blow past seals and enter seal bearings.
- Allow the machine to cool down before washing. Water on a warm machine can be sucked into sealed bearings as they cool.
- Avoid getting electrical connections wet. Water can cause electrical faults and corrosion of electrical components.

FastCat Pro

ENGINE COOLING

Continued operation with a clogged cooling system will cause severe overheating and can result in engine damage.

- **Daily:** Clean air intake screen **V**.
- **Every 100 hours:** Clean cooling fins beneath blower housing **H** with reference to information in the engine manufacturer's manual.

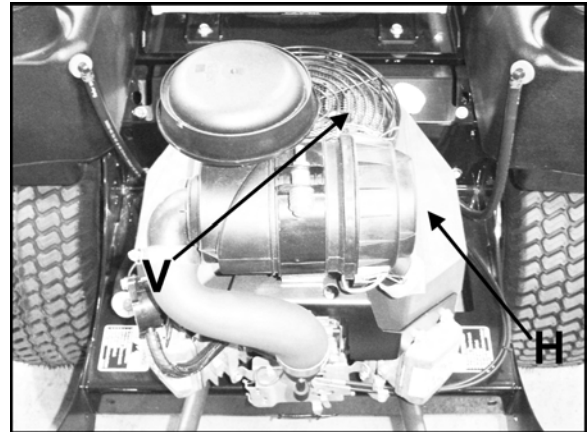

SPECIFIC TORQUES

BLADE BOLTS	70 FT-LBS (95 Nm)
WHEEL HUB NUTS	150 FT-LBS (203 Nm)
ENGINE CRANKSHAFT BOLT	50 FT-LBS (68 Nm)
TRANSAXLE PULLEY NUT	28.3 - 41.6 FT-LBS (38 - 56 Nm)
TRANSAXLE DRAIN PLUG	15 - 20 FT-LBS (20 - 27 Nm)
TRANSAXLE FILTER	130 - 150 in-lbs (14.6 - 16.9 Nm)

PURGING TRANSAXLES

Due to the effects air has on efficiency in hydrostatic drive applications, it is critical that it be purged from the system.

These purge procedures should be implemented any time a hydrostatic system has been opened to facilitate maintenance or any additional fluid has been added to the system.

Purging may be required if the unit shows any of the following symptoms:

- Noisy operation.
- Lack of power or drive after short term use.
- High operation temperature, excessive oil expansion.

1. Check the transaxle fluid, fill to proper level, if required.
2. Raise the drive wheels off the ground. Support unit with jack stands or other suitable means.
3. With the bypass valves open, and the engine running, slowly move the control levers in both forward and reverse directions 5 to 6 times. As air is purged from the unit, the oil level will drop.
4. With the bypass valve closed, and the engine running, slowly move the control levers in both forward and reverse directions 5 to 6 times.
5. Stop engine. Check the transaxle fluid level, add fluid as required.
6. It may be necessary to repeat steps 3-5 until all the air is completely purged from the system. When the transaxle moves forward and reverse at normal speed, purging is complete.

TRANSAXLES

⚠ WARNING

Inattention to proper safety, operation, or maintenance procedures could result in personal injury, or damage to the equipment. Schiller Grounds Care, Inc. recommends returning the machine to your authorized Schiller Grounds Care, Inc. dealer for service or repair.

Perform transaxle maintenance with the engine off, spark plug wires disconnected and PTO disengaged.

TRANSAXLE FLUID CHANGE

Change the transaxle fluid every 200 hours of operation. It is essential that the exterior of the transaxle be free of debris, prior to fluid maintenance.

1. Remove the three 1/4" filter guard screws and filter guard **A**. Remove the oil filter **B** from the transaxle and discard. Dispose of used oil in accordance with local requirements.
2. Wipe the filter base surface off and apply a film of new oil to the gasket of the new replacement filter. Install the new filter by hand, turn 3/4 to one full turn after the filter gasket contacts the filter base surface.
3. Re-install the filter guard and torque the three screws to 65 in. lbs. each.
4. Remove cap **C**, fill the transaxles through the expansion tank **D** with approximately 2 quarts of SAE 20W-50 engine oil PER TRANSAXLE.

CAUTION

Do not overfill! If you overfill the transaxle while the unit is "cold", it may overflow as it reaches normal operating temperatures. The oil level should not be above the manufacturer's suggestions. This will allow the space needed for the oil to expand as it warms up.

5. After starting engine, check the fluid level and continue to add oil to overflow tank **D** to fill line on tank.
6. Purge the transaxles, following the purging procedures on Page 31.

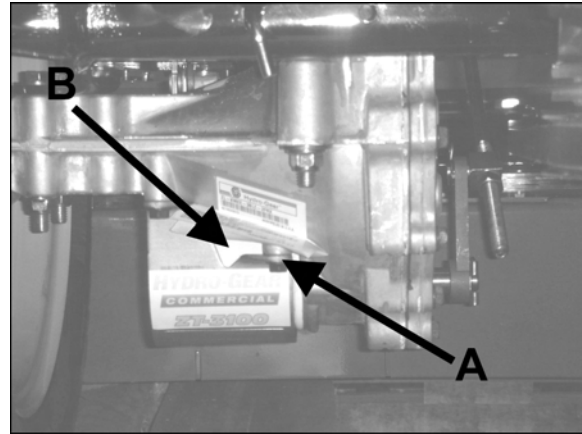

FastCat Pro

BLADE REMOVAL

Follow these instructions to prevent injury during blade removal:

1. Loosen with a box wrench or a socket and long breaker bar. To gain additional leverage, slip a long pipe or thick-walled tube over breaker bar or wrench.
2. Insert wood block **A** as shown, with grain perpendicular to blade, to prevent blade from turning when loosening.
3. Wear thickly padded gloves. Keep hands clear of blade path. Blades may rotate when bolt releases.

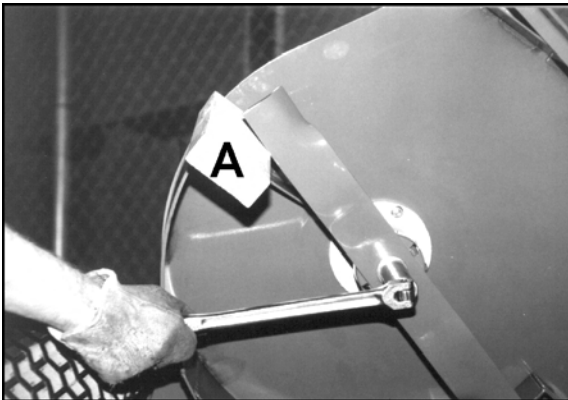

SHARPENING

Blades may be sharpened by filing or grinding.

- Inspect blades before sharpening.
- Replace bent or cracked blades.
- Replace blades when the lift portion has worn thin.
- Maintain cut angle at 30°.
- Do not overheat blades when sharpening.
- Always use Schiller Grounds Care, Inc. blades. Use of another manufacturer's blades may be dangerous.

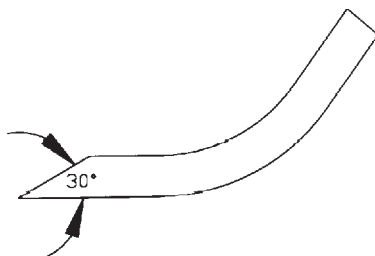

BLADE BALANCE

Blade balance must be maintained at 5/8 oz-in (19.4 g-cm) or less. Failure to keep blades balanced causes excess vibration, wear, and shortened life of most components of the machine.

To balance a blade:

1. Sharpen blade first.
2. Balance the blade at the center.
3. Attach a 1/8 oz (3.9 g) weight at a distance 5" (127 mm) from center on the light end. This should make the light end the heavy end:
 - If it does, the blade is balanced.
 - If does not, file or grind the heavy end until the addition of the weight makes the light end the heavy end.

BLADE INSTALLATION

1. Wear thickly padded gloves to prevent cuts from the sharp blade.
2. Insert the blade bolt, in order, through the conical washer (cup side toward the blade, as shown), the blade, and the blade spacer.
3. Install assembly on the blade spindle.
4. Torque the blade bolt to 70 ft-lbs.

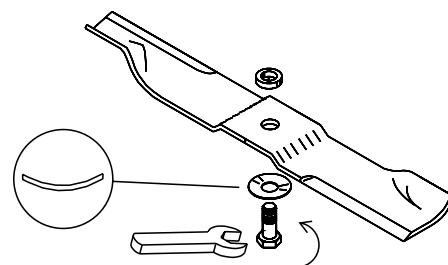

ADJUSTMENTS

FastCat Pro

DECK LEVELING

1. Park the machine on a smooth, level surface. Raise the deck to the transport position.
2. Lower the deck onto a set of equal height blocks under the rear corners of the deck. Place another set of blocks under the front of the deck so that the deck top is pitched forward 1/8".

NOTE: The front and rear of the deck are at different heights.

3. Measure the height of the blade cutting edge above the ground. Remove pin **B** and set the height of cut lever **E** to that height
4. Loosen nuts on bolts **G**. Move bolts in slot to remove slack in chain. Tighten nuts on bolts **G**.

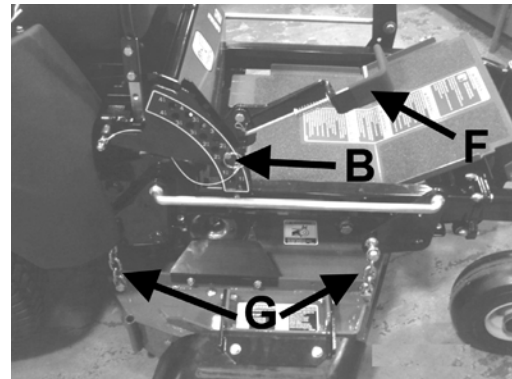

HEIGHT OF CUT

The height of cut is set by moving height of cut pin **B** to the hole designated for the height of cut desired.

To change the height of cut:

1. Lift the deck to the highest position.
2. Move pin **B** to the selected hole.
3. Lower the deck until the lift lever is stopped by the pin.

NOTES:

- Height of cut may vary due to the amount of tread on the tires, tire diameter or inflation pressure.

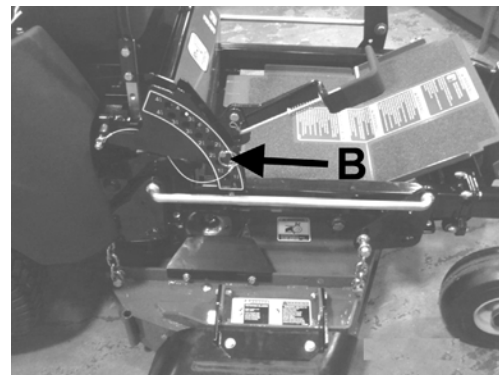

DECK ROLLERS

The deck rollers are adjustable up and down to provide improved deck flotation and scalping protection at various heights of cut. They are not intended to ride continuously on the ground. Adjust no closer than 3/8" (10mm) to the ground.

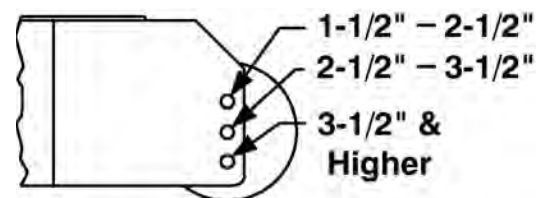

Height of cut ranges for roller adjustment

FastCat Pro

PARKING BRAKE

FOR 36", 48", AND 52" MODELS

NOTE: There are 2 brakes, 1 on each transaxle.

The parking brake should keep the machine from moving. To check the parking brake, park the machine on a level surface, open the bypass valves and set the parking brake to **ON**. Attempt to move the machine forward and backward by pushing it. If the machine moves, adjust the parking brake linkage as follows:

1. Move the machine to a flat horizontal surface.
2. Grip the flats on the brake rod **A**. Tighten nut **B** on the brake rod until you run out of threads. See Figure 1 for detailed view.
3. Move the parking brake handle to the **OFF** position.
4. Loosen nut **X**.
5. Hold brake arm in the **OFF** position as shown in Figure 2.
6. Adjust swivel **U** until swivel stud meets brake arm hole in the **OFF** position.
7. Insert cotter pin into swivel **U**.
8. Tighten nut **X**.
9. Repeat Steps 1-8 on the opposite side.

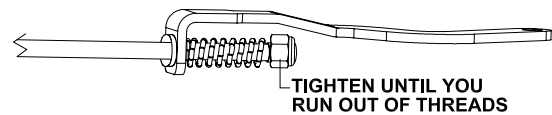
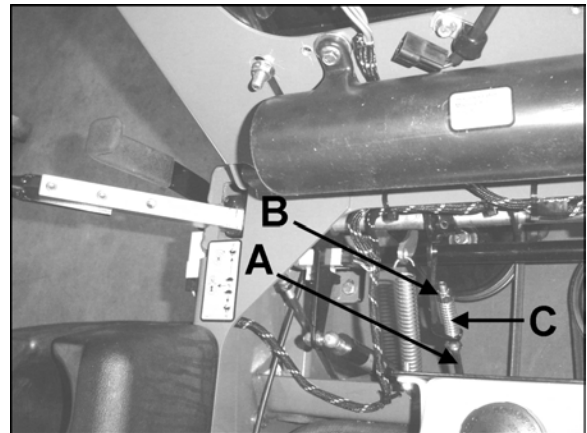

FIGURE 1

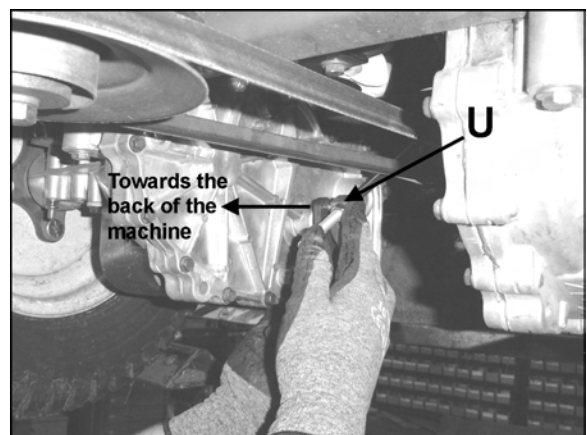
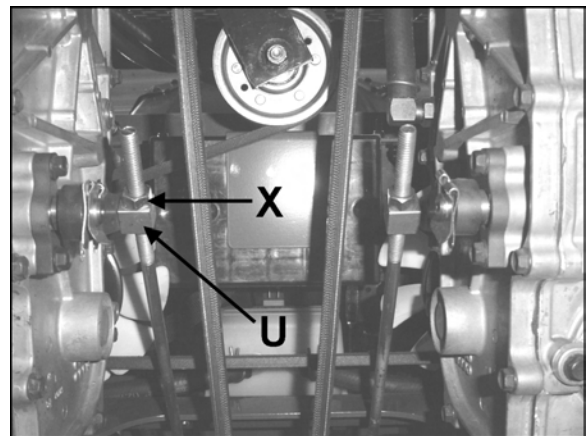

FIGURE 2

PARKING BRAKE FOR 61" MODELS

NOTE: There are 2 brakes, 1 on each transaxle.

The parking brake should keep the machine from moving. To check the parking brake, park the machine on a level surface, open the bypass valves and set the parking brake to **ON**. Attempt to move the machine forward and backward by pushing it. If the machine moves, adjust the parking brake linkage as follows:

1. Move the machine to a flat horizontal surface.
2. Grip the flats on the brake rod **A**. Tighten nut **B** on the brake rod until you run out of threads. See Figure 1 for detailed view.
3. Move the parking brake handle to the **OFF** position.
4. Loosen nut **X**.
5. Hold brake arm in the **OFF** position as shown in Figure 2.
6. Adjust linkage rod **U** until formed end of rod meets brake arm hole in the **OFF** position.
7. Insert cotter pin into formed end of linkage rod **U**.
8. Tighten nut **X**.
9. Repeat Steps 1-8 on the opposite side.

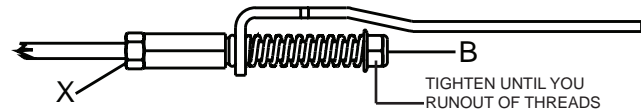
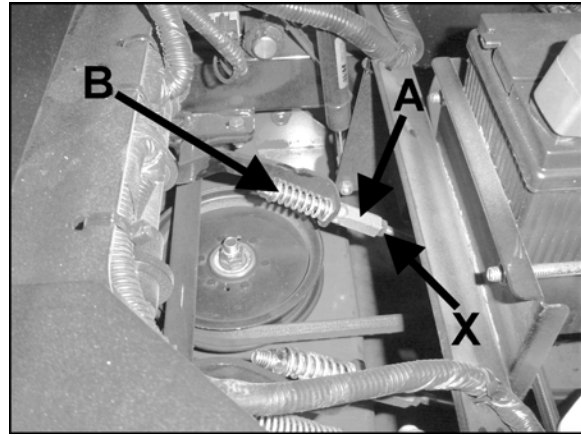

FIGURE 1

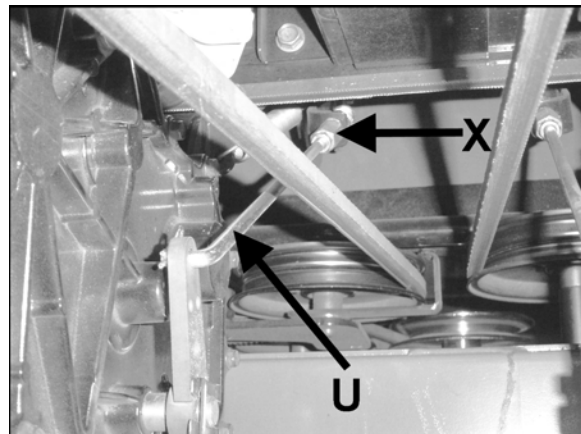
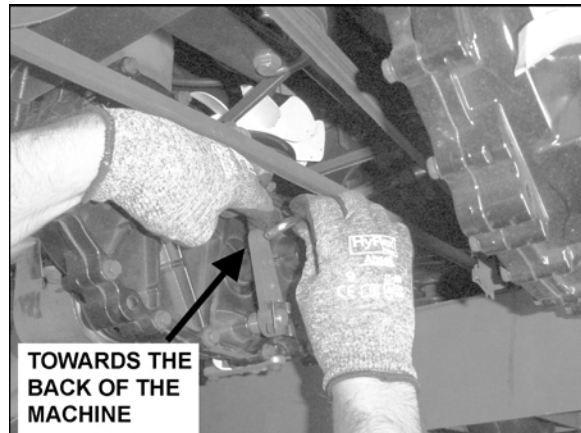

FIGURE 2

FastCat Pro

HYDROSTATIC TRANSAXLE ADJUSTMENTS

A turnbuckle style hydro stat neutral adjustment is provided.

Neutral:

1. Support the machine with the rear wheels off the ground. Use jack stands or equivalent support. Do not rely only on mechanical or hydraulic jacks.
2. Move the traction levers out into the neutral lock position and raise the seat.
3. Disconnect the seat switch wire and temporarily connect the two terminals with jumper wire **J** as shown.
4. Start the engine and run at low speed.
5. Move parking brake to the **OFF** position.
6. Loosen jam nuts **K** at both ends of the control rod **L**.
7. Rotate the control rod until the corresponding wheel stops turning. Lock the control rod jam nuts. Run the engine up to high idle and stroke the traction levers forward and back to check the adjustment. Move traction levers back to neutral and readjust if necessary.
8. Repeat steps 6 and 7 for the opposite side.
9. Remove the jumper wire and reconnect the seat switch.

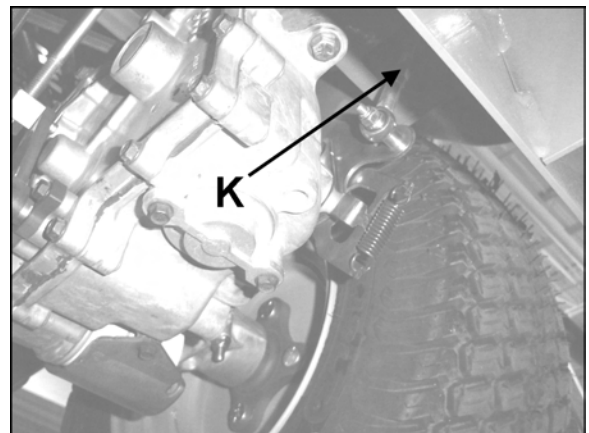
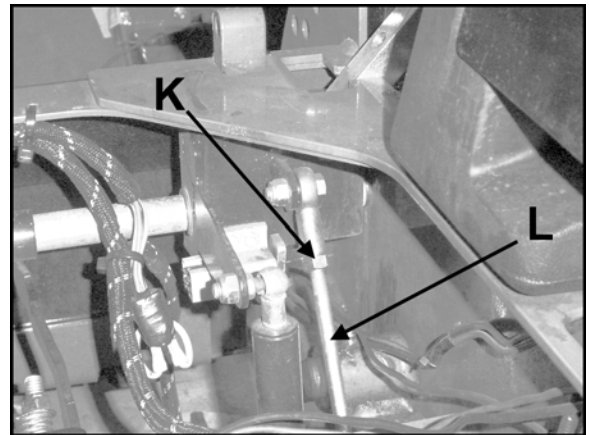
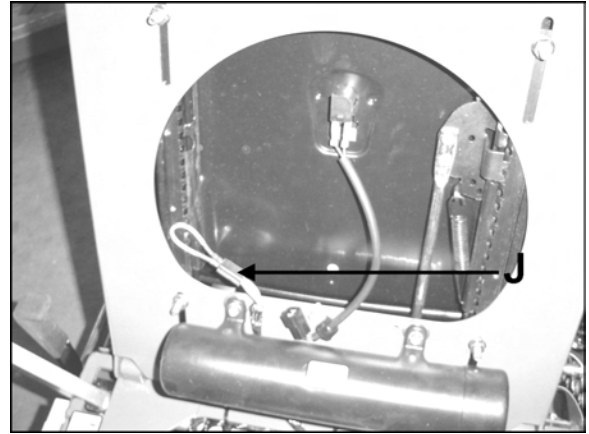

ARM REST HEIGHT ADJUSTMENTS

1. Remove acorn nuts **1**, plastic washers **2**, arm rest **3** and second set of plastic washers **4**.
2. Adjust carriage bolts **5** to desired height **A**, **B**, or **C** by pushingg on the carriage bolts **5** until they are free from the locking slot, adjusting them to the desired height and then pulling the carriage bolts **5** into the desired locking slot **A**, **B**, or **C**. Bolts must be placed into slots a like heights or arm rest will not fit.
3. Re-assemble washers **2** & **4**, arm rest **3**, and acorn nuts **1** in reverse order from disassembly. Hold carriage bolts **5** in locking slots while tightening acorn nuts **1** to prevent them from falling out of the locking slots. Tighten nuts **1** until desired resistance in arm rest rotation is acheived.

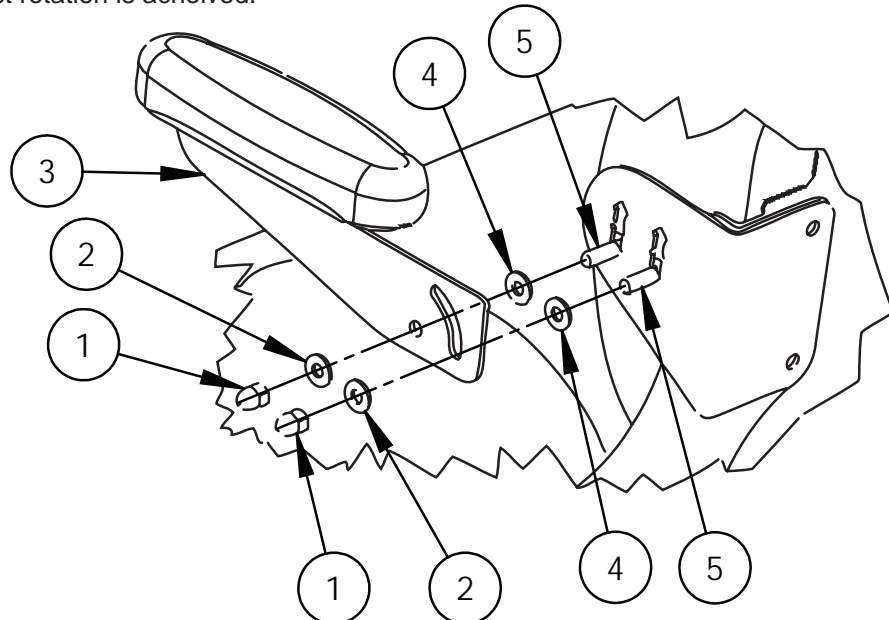
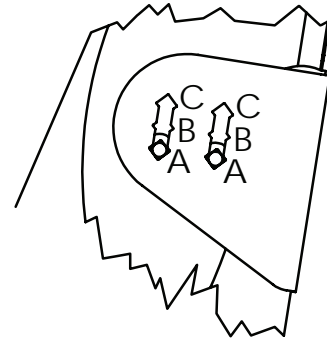

SEAT ADJUSTMENT

The seat plate allows from some seat adjustment either forward or backward.

1. Flip seat up.
2. Use holes **1** or **2** for seat adjustment.
DO NOT USE holes **3** or **4** due to space restrictions with the document tube.

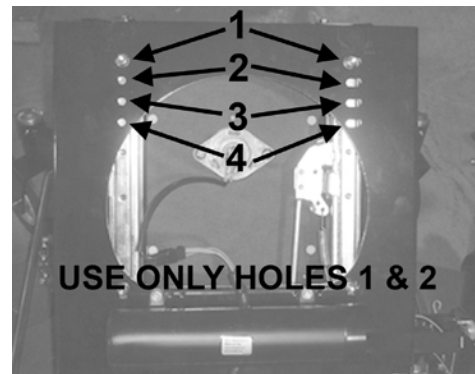

FastCat Pro

NOTE: Always use Schiller Grounds Care, Inc. replacement belts, not general purpose belts. Schiller Grounds Care, Inc. belts are specially designed for use on this mower and will normally last longer.

CUTTERDECK BELT

1. Remove floorplate.
2. Set the cutterdeck in a middle height-of-cut position.
3. Use a 3/8" ratchet and extension to back tensioning idler off to remove belt from idler. Remove belt from cutterdeck pulleys.

NOTE: Use the 3/8" ratchet in the square hole **A** on the idler.

4. Remove belt from clutch pulley.
5. Install the new belt by performing these steps in reverse order.

NOTE: 61" cutterdeck may require tension spring adjustment after belt installation. See Belt tension

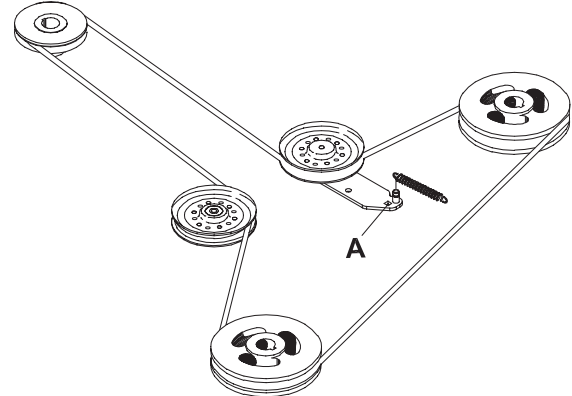

2 SPINDLE DECK

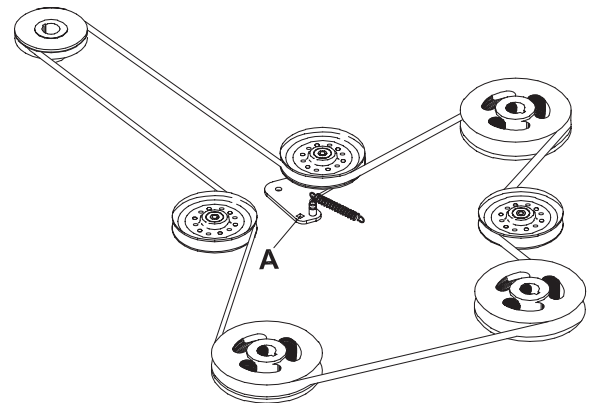

3 SPINDLE DECK

BELT TENSION FOR 61" DECK

All belts are tensioned by spring loaded idlers and do not require any adjustment except for the 61" cutterdeck. Use the eyebolt to adjust the spring length to be between 6 3/4" - 7 1/2" as pictured.

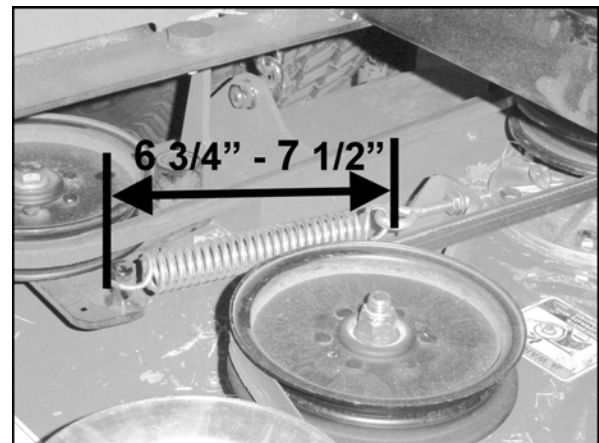

BELT REPLACEMENT

FastCat Pro

NOTE: Always use Schiller Grounds Care, Inc. replacement belts, not general purpose belts. Schiller Grounds Care, Inc. belts are specially designed for use on this mower and will normally last longer.

HYDRO TRANSAXLE DRIVE BELT

1. Remove cutterdeck belt (see cutterdeck belt replacement).
2. Disconnect wire **I** at clutch **M**. Remove bolts **J** and remove torque restraint.
3. Using a ratchet with a 9/16" socket, place over nut at location **P**. Use the ratchet to rotate it enough to remove the transaxle drive belt.
4. Install a new transaxle drive belt by performing these steps in reverse order.
5. Inspect the fans. Replace if worn or damaged. Torque transaxle pulley nut to 28.3-41.6 ft-lbs (38-56 Nm).
6. Reinstall cutterdeck belt (see cutterdeck belt replacement).

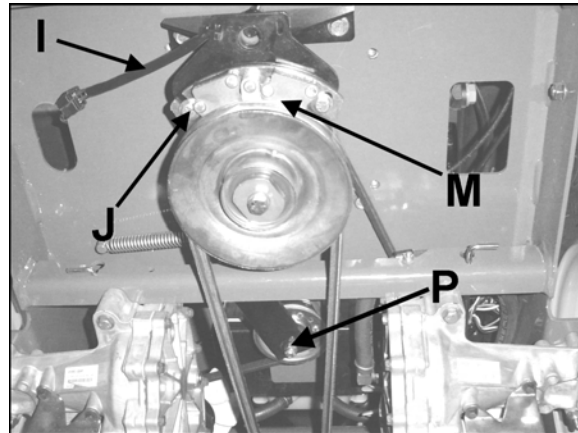

FRAME-ENGINE/CLUTCH ASSY

FastCat Pro

FIGURE 1

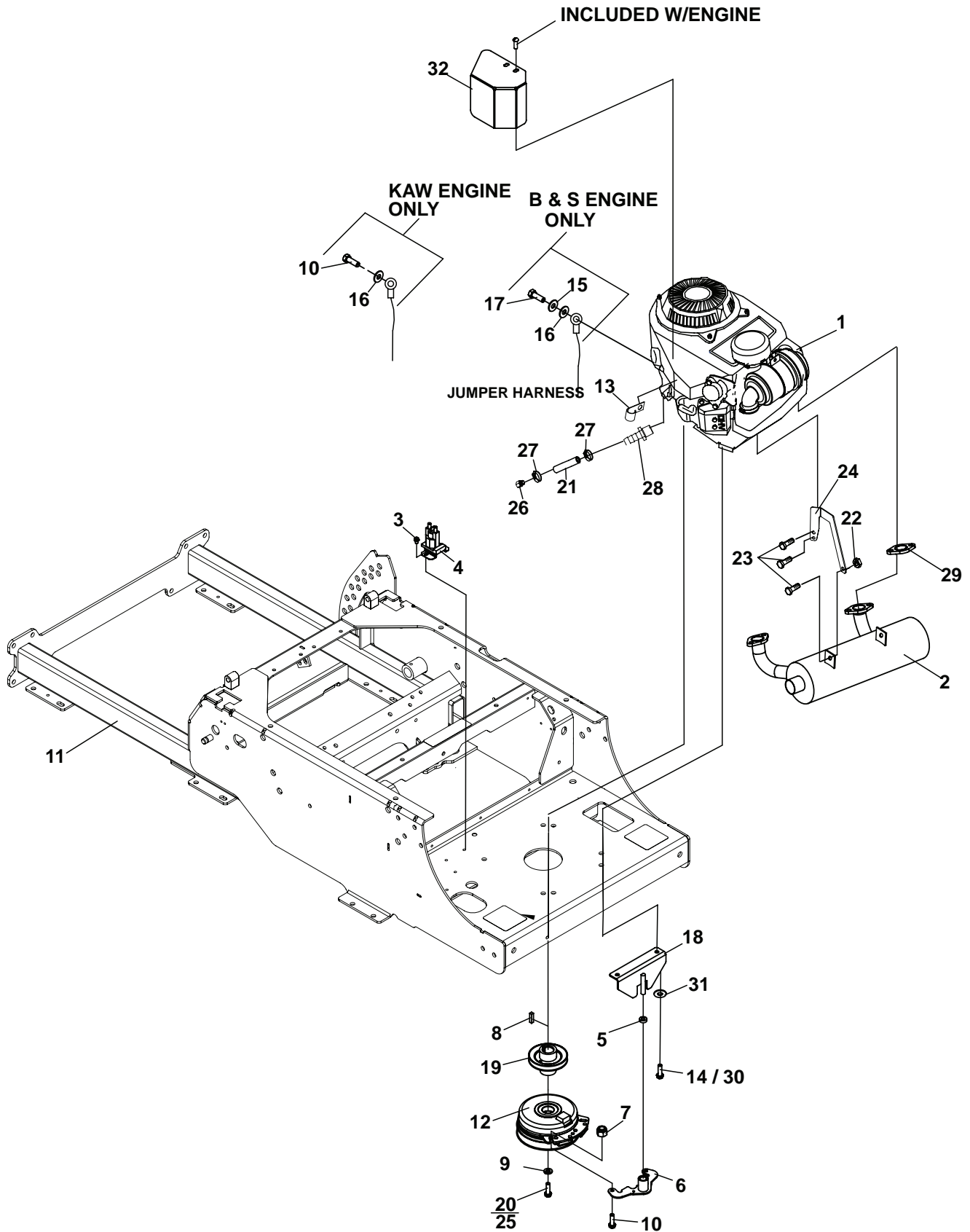

FIGURE 1

ITM	PART NO.	DESCRIPTION	QTY	ITM	PART NO.	DESCRIPTION	QTY
1	4164364	ENGINE-FX541V KAW	1	15	64006-02	LOCKWASHER-HELICAL 5/16 (USED ON MODEL 942404G ONLY)	1
	4164366	ENGINE-FX600V KAW	1	16	64163-55	WSHR .328X.75X14 GA	1
	38666	FILTER-FUEL		17	64223-11	SCH CAPSCREW M8-1.25X16 (USED ON MODEL 942404G ONLY)	1
	4164537	FILTER-OIL		18	4144112.7	WLDMT-CLUTCH BRACKET	1
	4164329	FILTER-AIR		19	4163309	PULLEY-ENGINE	1
	(USED ON MODELS 942297G, 942298G & 942302G)			20	64123-78	BOLT-HEX 7/16-20X2-1/2 (USED ON 942299G, 942404G & 942405G)	1
	4164366	ENGINE-FX651V KAW	1	21	69053-13	HOSE-HTDRO, 3/8X14"	1
	4164367	ENGINE-FX691V KAW	1	(ITEMS 22-24 USED ON KAW ENGINES ONLY)			
	38666	FILTER-FUEL		22	64266-02	NUT-FL LOCK M8-1.25	2
	4164630	FILTER-AIR		23	64263-002	BLT-FLG HD M6-1.0 X 16	6
	4164631	FILTER-SAFETY		24	4164442.7	BRKT-MUFFLER LH	1
	4164537	FILTER-OIL			* 4164443.7	BRKT-MUFFLER RH	1
	(USED ON MODELS 942299G & 942405G)			25	64123-55	BLT-HEX 5/16-18X3 (USED ON MODEL 942404G & 942405G ONLY)	1
	4163987	ENGINE-627cc VANGRD B&S	1	26	4164251	VAILVE-OIL DRAIN	1
	38666	FILTER-FUEL		27	88042-03	CLAMP-HOSE	2
	4164152	ELEMENT-AIR		28	4164252-001	FITTING-3/8NP TO BARB	1
	4164153	FILTER-OIL		29	11061-7061	GASKET-MUFFLER (AVAILABLE FROM KAWASAKI DEALER)	2
	(USED ON MODEL 942404F)				806425	GASKET-MUFFLER (AVAILABLE FROM B&S DEALER)	
2	4164386	MUFFLER-KAW (USED ON MODEL 942297G, 942298G & 942302G)	1	(ITEMS 30-32 USED ON KAWASAKI UNITS ONLY)			
	4164385	MUFFLER -KAW (USED ON MODELS 942299G & 942405G)	1	30	64123-70	BLT-HEX 3/8-16X1-1/2	4
	4163913	MUFFLER-B&S (USED ON MODEL 942404G)	1	31	64006-03	LOCKWSHR-3/8 HELICAL	4
3	64152-23	1/4-20X3/8 LG SP SCREW	2	32	4162803.7	DEFLECTOR-AIRFLOW (USED ON 942404G ONLY)	1
4	38665	SOLENOID (ITEMS 3 & 4 USED ON 942299G, 942404G, & 942405G)	1				
5	38304-03	BRG-FLANGED PLASTIC	1				
6	2721331.7	WLDMT-CLUTCH STOP	1				
7	64265-04	LOCKNUT-M8-1.25	2				
8	64164-12	KEY-1/4X1/4X1 SQ END	1				
9	64006-06	LOCKWASHER-HEL 7/16	1				
10	64205-001	BLT-MET M8-1.25X20	3				
11	4164049	S-FRAME W/ LABELS	1				
12	4144116	CLUTCH-ENGINE PULLEY	1				
13	48412-01	CLAMP	1				
14	64197-005	BLT-TDFM 3/8-16X1-1/4	4				

* NOT ILLUSTRATED

TRANSAXLE ASSY

FastCat Pro

FIGURE 2

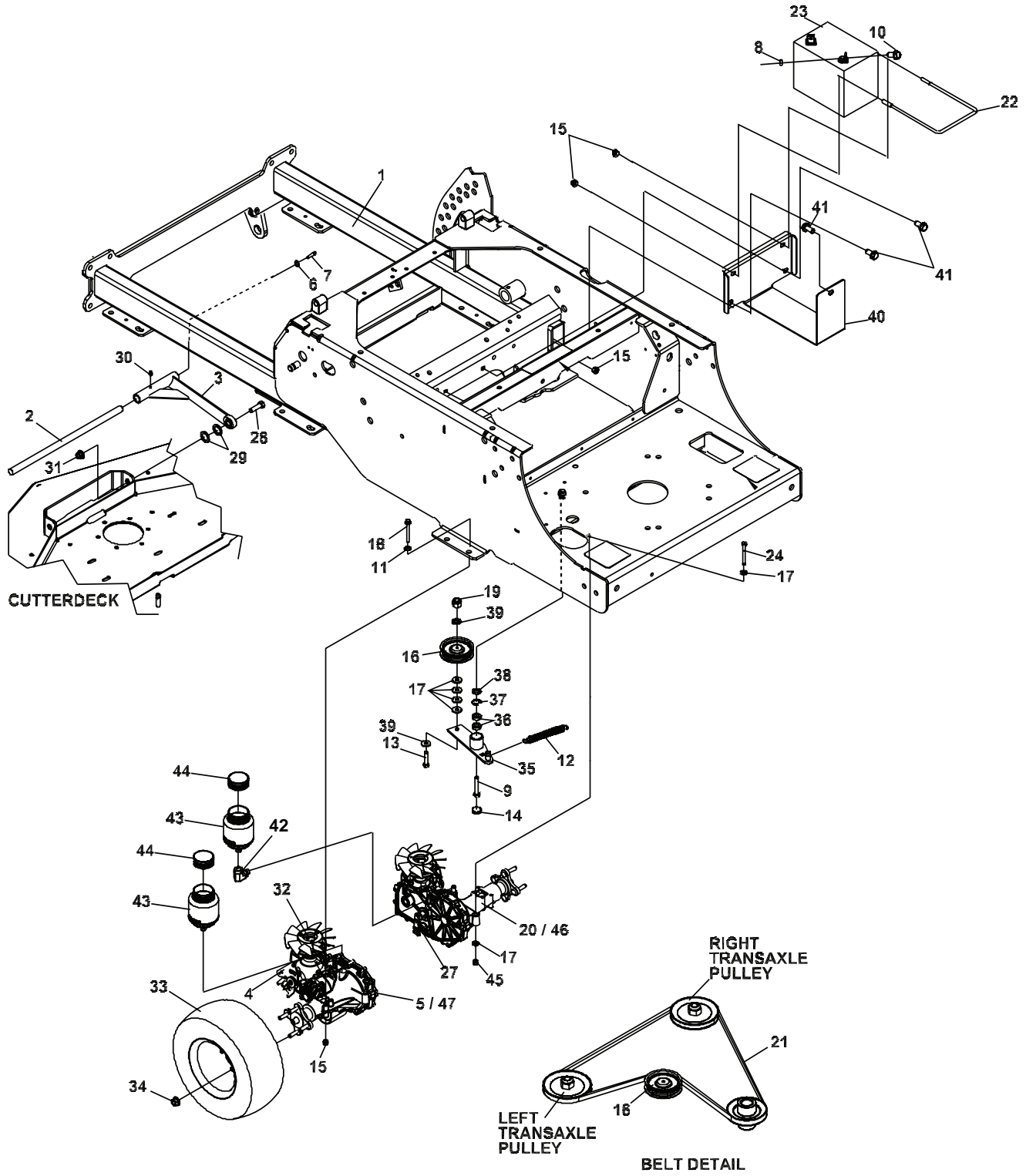

FIGURE 2

ITM	PART NO.	DESCRIPTION	QTY	ITM	PART NO.	DESCRIPTION	QTY
1	4164049	S-FRAME W/LABELS	1				
2	4162973	SHAFT-PULLARM MOUNT	1				
3	4163957.7	WLDMT-PULL ARM	2				
4	4163819	ARM-CONTROL	2				
5	4156464	AXLE-LH	1				
		(INCLUDES ITEMS 4, 25, 26, 27, 32, 39 & 40)					
		(USED ON 36", 48" AND 52" DECKS ONLY)					
6	64163-29	WASHER	2				
7	64123-68	BOLT-HEX 5/16-18X1	2				
8	64025-02	NUT-HEX 5/16-18	2				
9	64270-01	BOLT-MET, HEX M10-1.5x30	1				
10	64123-54	BOLT, 5/16-18X3/4 HEX	2				
11	64163-55	WASHER .328X.75X14 GA	6				
12	4164128	SPRING-TENSION	1				
13	64123-67	BLT-HEX 3/8-16 X 2	1				
14	4128001	END CAP-24 X 7	1				
15	64268-02	NUT-FL NYLON LOCK 5/16-18	10				
16	2228016	PULLEY-IDLER PUMP	1				
17	64163-31	WASHER, 25/64X1X12	12				
18	64123-55	BLT-HEX 5/16-18X3	4				
19	64229-03	LOCKNUT-NYLON 3/8-16	1				
20	4156465	AXLE-RH	1				
		(INCLUDES ITEMS 4, 25, 26, 27, 32, 39 & 40)					
		(USED ON 36", 48" AND 52" DECKS ONLY)					
21	4143636	BELT-TRANSAXLE	1				
22	4163276	ROD-BATTERY CLAMP	2				
23	108055	BATTERY	1				
24	64123-88	BLT-HEX 3/8-16X2-3/4	4				
25*	4142045-06	FILTER-TRANSAXLE	2				
26*	4163819	SPRING-CONTROL ARM	2				
27	4163820	ARM-BRAKE	2				
28	64123-168	BLT-HEX 5/8-11X2-1/2	2				
29	64163-93	WSHR-.635 X 1.12 X.062	4				
30	85010N	ZERK, 1/4-28	4				
31	64229-06	LOCKNUT, NYLON 5/8-11	2				
32	4164048	KIT-FAN/PULLEY TRANSAXLE	2				
		(USED ON 36", 48", AND 52" DECKS ONLY)					
	4164129	KIT-FAN/PULLEY TRANSAXLE	2				
		(USED ON 61" DECKS ONLY)					
				33	4142752	TIRE-ASSY 20 X 8 - 10 4 PLY	2
					4142752-01	20X8-10 4 PLY MULTI TRAC TIRE	
					4132433-03	WHEEL-10X7	
						(USED ON 48" DECKS ONLY)	
					4163731	TIRE-ASSY 20 X 6.50 - 10	2
					4163731-01	WHEEL-10X5.375	
					4163731-02	TIRE-20X6.5-10 GRASSMASTER	
						(USED ON 36" DECKS ONLY)	
					4155841	TIRE-ASSY 20 X 10-10	2
					4132433-01	TIRE-20X10-10 4PLY TURFMASTER	
					4155841-01	WHEEL-10X7	
						(USED ON 52" DECKS ONLY)	
					4163964	TIRE-ASSY 23X10.50-12	2
					4158422-01	WHEEL -4-HOLE W/VALVE	
						(USED ON 61" DECKS ONLY)	
				34	64187-03	WHEEL NUT 1/2-20	8
				35	4133302	S-ASSY-IDLER ARM PUMP	1
						(INCLUDES ITEMS 36-38)	
				36	4128004	BEARING-BALL 10X26X8	2
				37	64144-40	SNAP RING-26MM INTERNAL	1
				38	4128000	SEAL-16X26X7	1
				39	64163-61	WASHER	2
				40	4167258.7	TRAY-BATTERY	1
				41	64197-022	BLT-TDFM 3/8-16X3/4	3
				42	4163264-01	ADAPTER-90 #6 MAORB/#6 FORB	1
				43	4163307	ASSY-EXPANSION TANK	2
				44	4142808-01	CAP-HYDRO TANK	2
				45	64268-03	NUT-FL NYLON LOCK 3/8-16	4
				46	4163772	TRANSAXLE-LH	1
						(USED ON 61" DECK ONLY)	
				47	4163771	TRANSAXLE-RH	1
						(USED ON 61" DECK ONLY)	
				48*	4164227	CHARGE PUMP COVER KIT	1
						(USED ON KAWASAKI ENGINES ONLY)	
					*4164228	CHARGE PUMP COVER KIT	1
						(USED ON B & S ENGINES ONLY)	

*** NOT ILLUSTRATED**

FUEL TANK/BUMPER & CONTROL PANEL

FastCat Pro

FIGURE 3

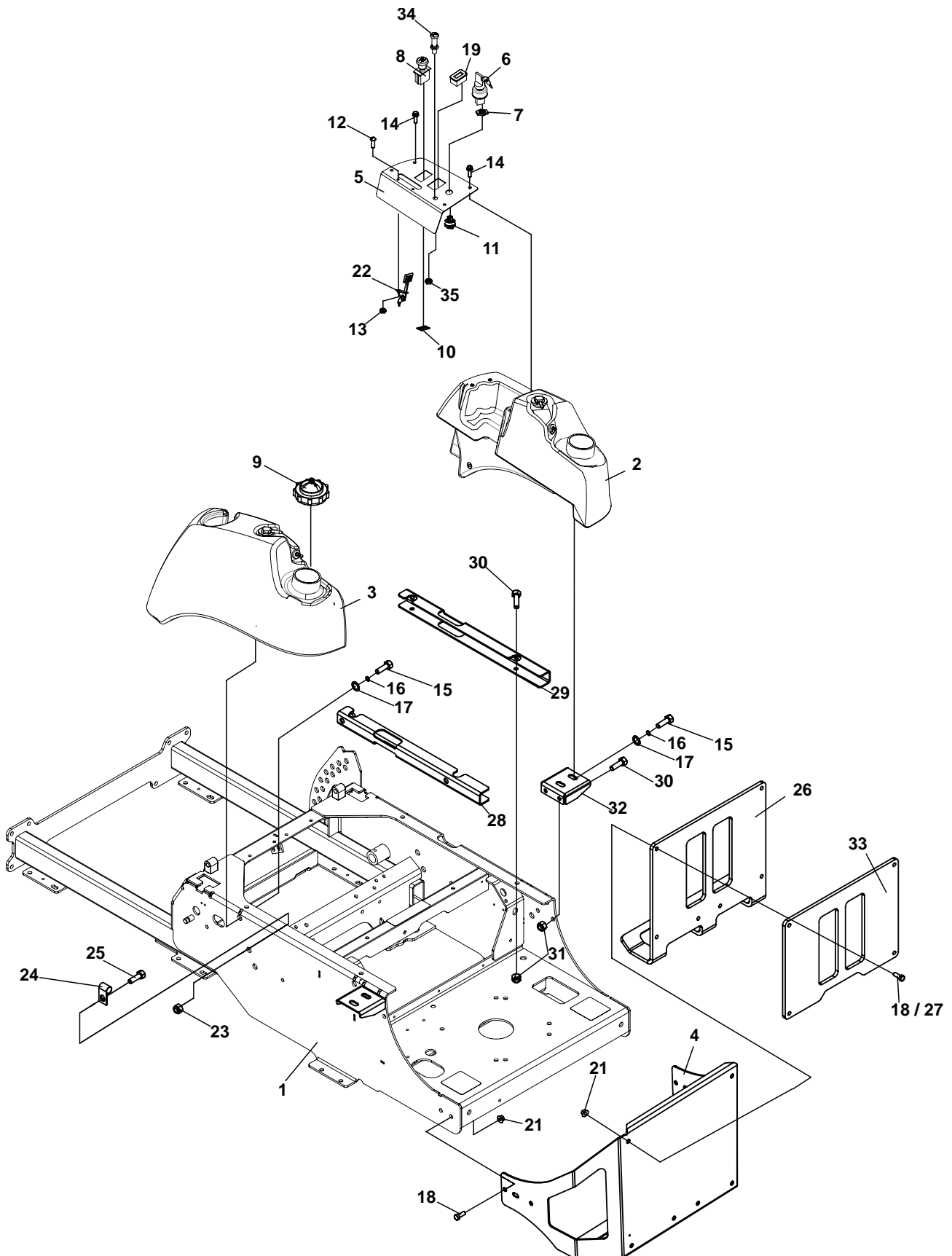

FUEL TANK/BUMPER & CONTROL PANEL

FastCat Pro

FIGURE 3

ITM	PART NO.	DESCRIPTION	QTY	ITM	PART NO.	DESCRIPTION	QTY
1	4164049	S-FRAME W/LABS	1				
2	4165504	TANK-FUEL RH	1				
3	4165503	TANK-FUEL LH	1				
4	4163041.7	BUMPER	1				
		(USED ON 36", 42", 48" AND 52" DECKS)					
	4164221.7	BUMPER	1				
		(USED ON 61" DECKS ONLY)					
5	4166245	S-CONTROL PANEL	1				
6	128010-03	S-COVERED KEY	1				
7	128010-01	S-KEY SWITCH NUT 5/8-32	1				
8	2721505	SWITCH-PTO	1				
9	4165291	CAP-FUEL TANK	2				
10	2188178	SWITCH-RETAINER	1				
11	128010	SWITCH, KEY	1				
12	64152-46	SCREW-SLT HH 10-24X1/2	2				
13	64025-15	NUT-HEX #10-24 KEPS	2				
14	64262-001	BLT-FLG HD 1/4-20 X 1/2	4				
15	64123-50	BOLT-3/8-16X1 HEX	10				
16	64006-03	WASHER-3/8	10				
17	64163-69	WASHER-FLAT	10				
18	64262-010	BLT-FLG HD 3/8-16 X 3/4	4				
19	4136792	METER-HOUR	1				
20*	4144213	TUBE-FUEL FEED	2				
21	64268-03	NUT-WLF 3/8-16	4				
22	118020-17	CONTROL-THROTTLE	1				
23	64229-02	LOCKNUT-5/16-18	2				
24	48228-12	CLAMP-3/4 CLIP	2				
25	64123-54	BLT-HEX 5/16-18X3/4	2				
26	4163901.7	WEIGHT-COUNTER	1				
27	64262-018	BLT-FLG HD 3/8-16 X 1-3/4	4				
		(USED ON 61" DECKS ONLY)					
28	4163895.7	CHANNEL-TANK SPACER, LH	1				
		(USED ON 61" DECKS ONLY)					
29	4164022.7	CHANNEL-TANK SPACER, RH	1				
		(USED ON 61" DECKS ONLY)					
30	64123-50	BOLT-HEX 3/8-16X1	8				
31	64229-03	NUT-NYLON LOCK 3/16-18	8				
32	4163880.7	BRKT-TANK MOUNTING	2				
33	4163905.7	PLATE-WEIGHT	1				
34	108009-04	CABLE-CHOKE	1				
35	64025-04	NUT-HEX 3/8-24	1				

* NOT ILLUSTRATED

FUEL VALVE & COVER PLATE

FastCat Pro

FIGURE 4

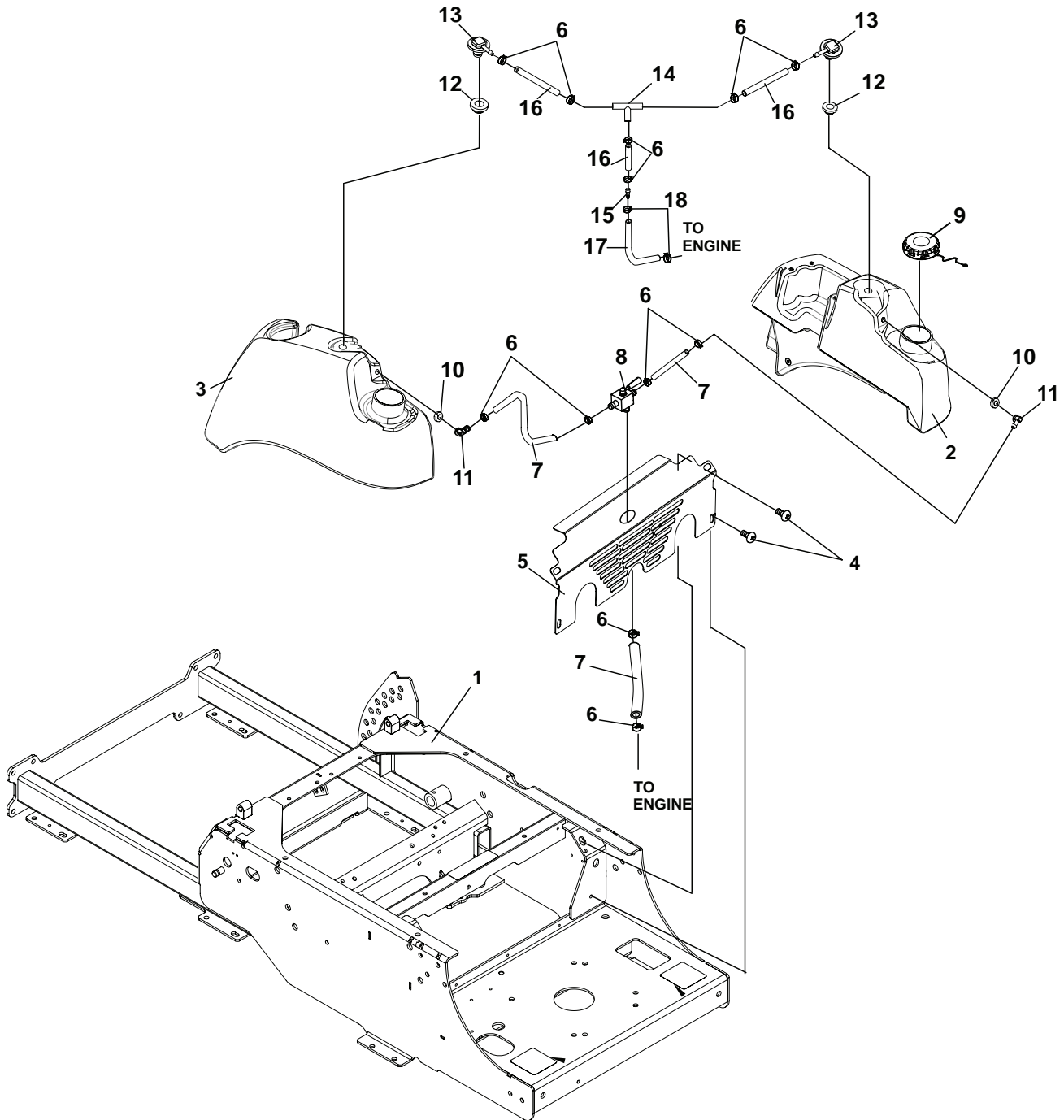

ITM	PART NO.	DESCRIPTION	QTY	ITM	PART NO.	DESCRIPTION	QTY
1	4164049	S-FRAME W/LABS	1				
2	4165504	TANK-FUEL RH BOBCAT (INCLUDES 10-13, 19-21)	1				
3	4165503	TANK-FUEL LH BOBCAT (INCLUDES 10-13, 19-21)	1				
4	64197-001	BLT-TDFM 5/16-18X3/4	4				
5	4146655.7	COVER-FRAME, REAR	1				
6	88042N	HOSE CLAMP	12				
7	4162977-001	HOSE-1/4 FUEL LINE 24"	3				
8	2188161	VALVE-TANK SELECTOR	1				
9	4165291	CAP-FUEL TANK	2				
10	4132325	GROMMET-FUEL TANK	2				
11	4165667	FITTING-BARBED 90 DEG	2				
12	4165387	GROMMET-ROLL OVER	2				
13	4165763	ROLLOVER VENT	2				
14	4165863	TEE-FITTING 1/4"HOSE	1				
15	4165864	FITTING-HOSE 1/4" TO 3/16"	1				
16	4162977-020	HOSE-FUEL LINE	3				
17	4162989-001	HOSE-FUEL LINE	1				
18	88042-01	CLAMP	2				
19*	4165692-01	FUEL-LINE TANK	2				
20*	4165668	FILTER-FUEL	2				
21*	4166704	CLAMP-FUEL	2				

DECK LIFT ASSEMBLY

FastCat Pro

FIGURE 5

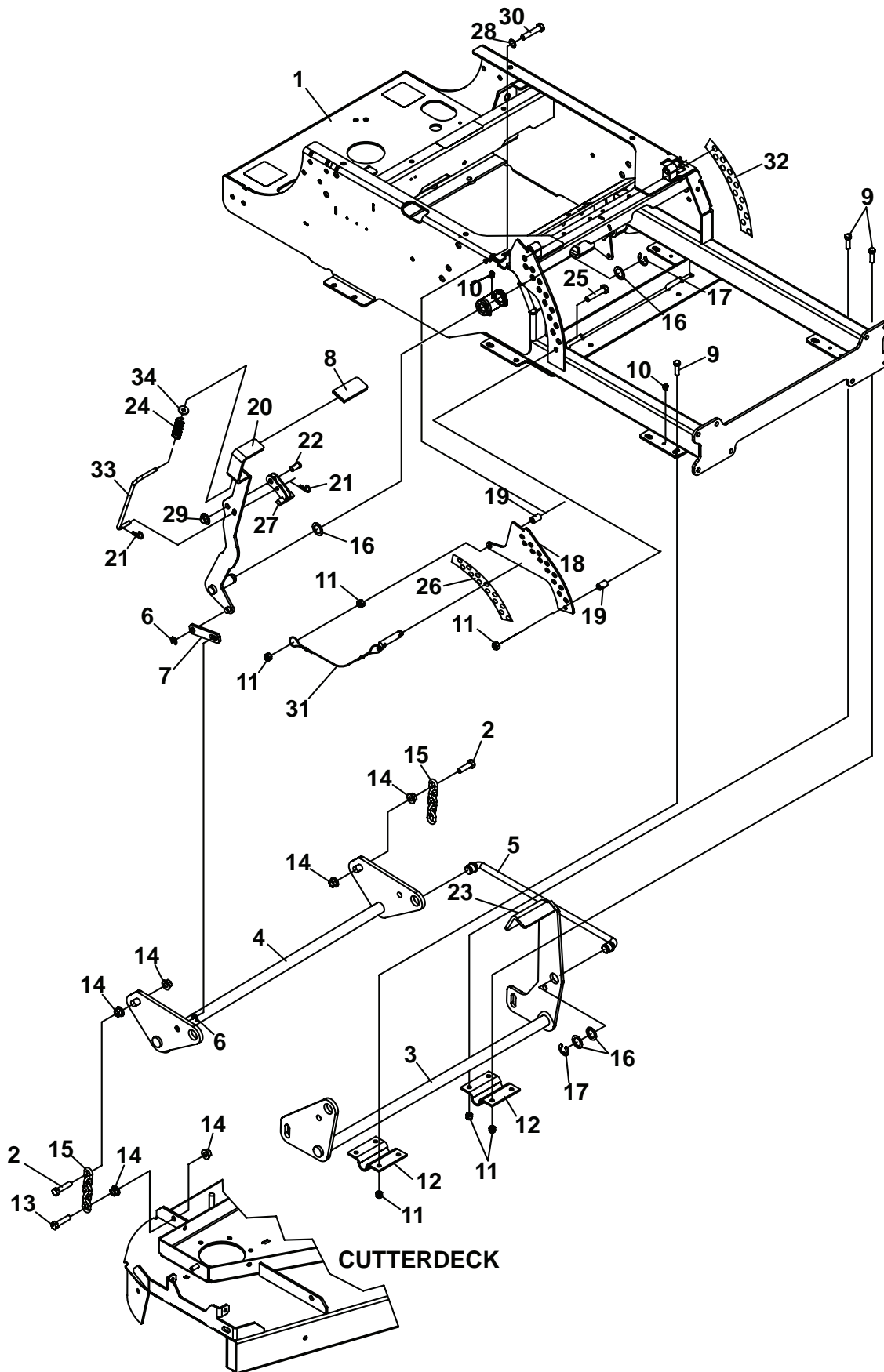

ITM	PART NO.	DESCRIPTION	QTY	ITM	PART NO.	DESCRIPTION	QTY
1	4164049	S-FRAME W/LABS	1				
2	64205-060	BOLT-MET M12-1.75X50	4				
3	4164565.7	WLDMT-DECKLIFT, FRONT	1				
4	4163894.7	WLDMT-DECKLIFT REAR	1				
5	4109960	WLDMT-DECK LIFT ROD	2				
6	64221-02	E-RING .250	2				
7	4163891.7	BRKT-LIFT LINK	1				
8	2188143	GRIP	1				
9	64123-50	BOLT-HEX 3/8-16X1	15				
10	85010N	ZERK, 1/4-28 STR	5				
11	64229-03	LOCKNUT-NYLON 3/8-16	19				
12	2182356.7	BRACKET-SHAFT HANGER	4				
13	64205-029	BLT-MET M12X1.75X40	4				
14	64246-04	NUT-WHIZ M12-1.75	16				
15	2188127	CHAIN-6.35 (.250) 5 LINKS	4				
16	64163-65	WASHER-.890X1.375X18GA	10				
17	64221-04	E-RING.875	5				
18	4143575.7	BRKT-OUTER DECK LIFT	1				
19	2183071-03	SPACER-15.88X10.32X24	2				
20	4163893.7	LEVER-DECK LIFT	1				
21	64168-2	COTTER-HAIRPIN.08X1.19	2				
22	64188-53	PIN-CLEVIS 1/2X1.0	1				
23	4139785	MAT-FOOT LIFT	1				
24	2720544	SPRING-COMPRESSION	1				
25	64123-67	BLT-HEX 3/8-16X2	1				
26	4126611	LABEL-H.O.C. OUTER,	1				
27	4162904.7	WLDMT-LVR STOP LATCH	1				
28	64163-31	WASHER	1				
29	64175-05	PUSHNUT-1/2 DIA	1				
30	64123-82	BOLT-HEX 3/8-16X2-1/2	1				
31	4159060	ASSY, PIN & LANYARD	1				
32	2720743	LBL-HT CUT INNER	1				
33	4159284	ROD-LIFT STOP	1				
34	64163-29	WASHER-21/64X1X11GA	1				

CASTER ASSEMBLY

FastCat Pro

FIGURE 6

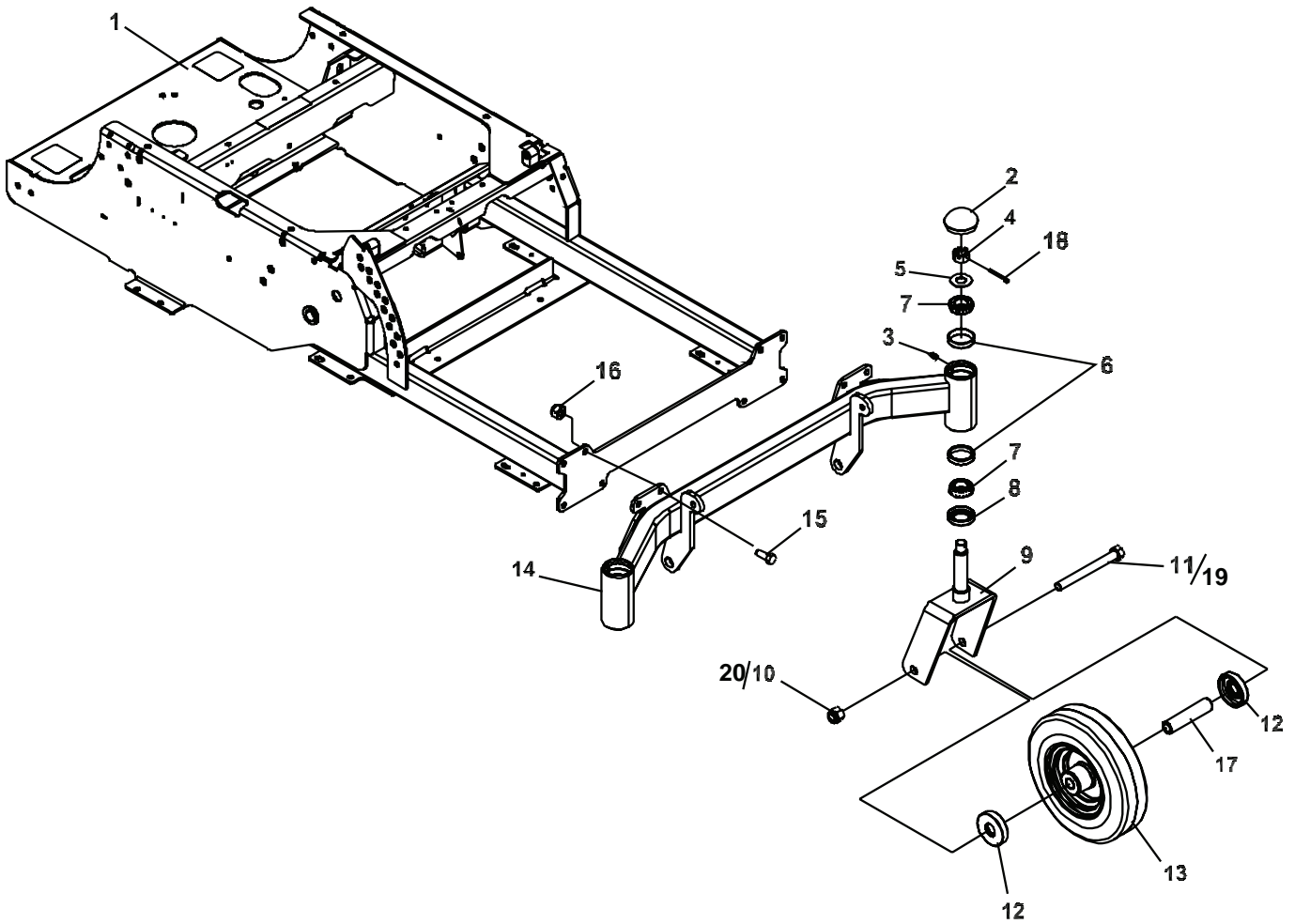

ITM	PART NO.	DESCRIPTION	QTY	ITM	PART NO.	DESCRIPTION	QTY
1	4164049	S-FRAME W/LABS	1				
2	4162986	DUST COVER	2				
3	85010N	ZERK-1/4-28	2				
4	64025-20	NUT-HEX 3/4-16 SLOT U	2				
5	64163-26	WASHER	2				
6	48043-03C	CUP-OUTER BEARING	4				
7	48043-04C	CONE-OUTER BEARING	4				
8	48480	SEAL	2				
9	4143675.7	WLDMT-CASTER	2				
		(USED ON 36", 42", 48" AND 52" DECKS ONLY)					
	2721306.7	WLDMT-CASTER					
		(USED ON 61" DECKS ONLY)					
10	64229-06	LOCKNUT-NYLON 5/8-11	2				
		(USED ON 36", 42", 48" AND 52" ONLY)					
11	64123-212	BOLT-5/8-11X6.00	2				
		(USED ON 36", 42", 48" AND 52" ONLY)					
12	2722231	SPACER-END	4				
13	2722233	WHEEL-11"ASSY-LT TYPE	2				
		(USED ON 36", 42", 48" AND 52" ONLY)					
	2722228	WHEEL-ASSY 13x5.00-6	2				
		(USED ON 61" ONLY)					
14	4162945.7	WLDMT-CSTR MOUNTING	1				
		(USED ON 48" & 52" ONLY)					
	4162974.7	WLDMT-CSTR MOUNTING	1				
		(USED ON 36" & 42" ONLY)					
	4163578.7	WLDMT-CSTR MOUNTING	1				
		(USED ON 61" ONLY)					
15	64123-16	BLT-HEX 3/8-16X1-1/4	8				
16	64229-03	LOCKNUT-NYLON 3/8-16	8				
17	2722230-01	SPANNER-11" WHEEL	2				
		(USED ON 36", 42", 48" AND 52" ONLY)					
	2722230-02	SPANNER-13" WHEEL					
		(USED ON 61" ONLY)					
18	304636	COTTER PIN	2				
19	64123-215	BLT-HEX 3/4-10 X 7 1/2	2				
		(USED ON 61" ONLY)					
20	64229-07	LOCKNUT-NYLON 3/4-10	2				
		(USED ON 61" ONLY)					

KICKPLATE/SEAT ASSEMBLY

FastCat Pro

FIGURE 7

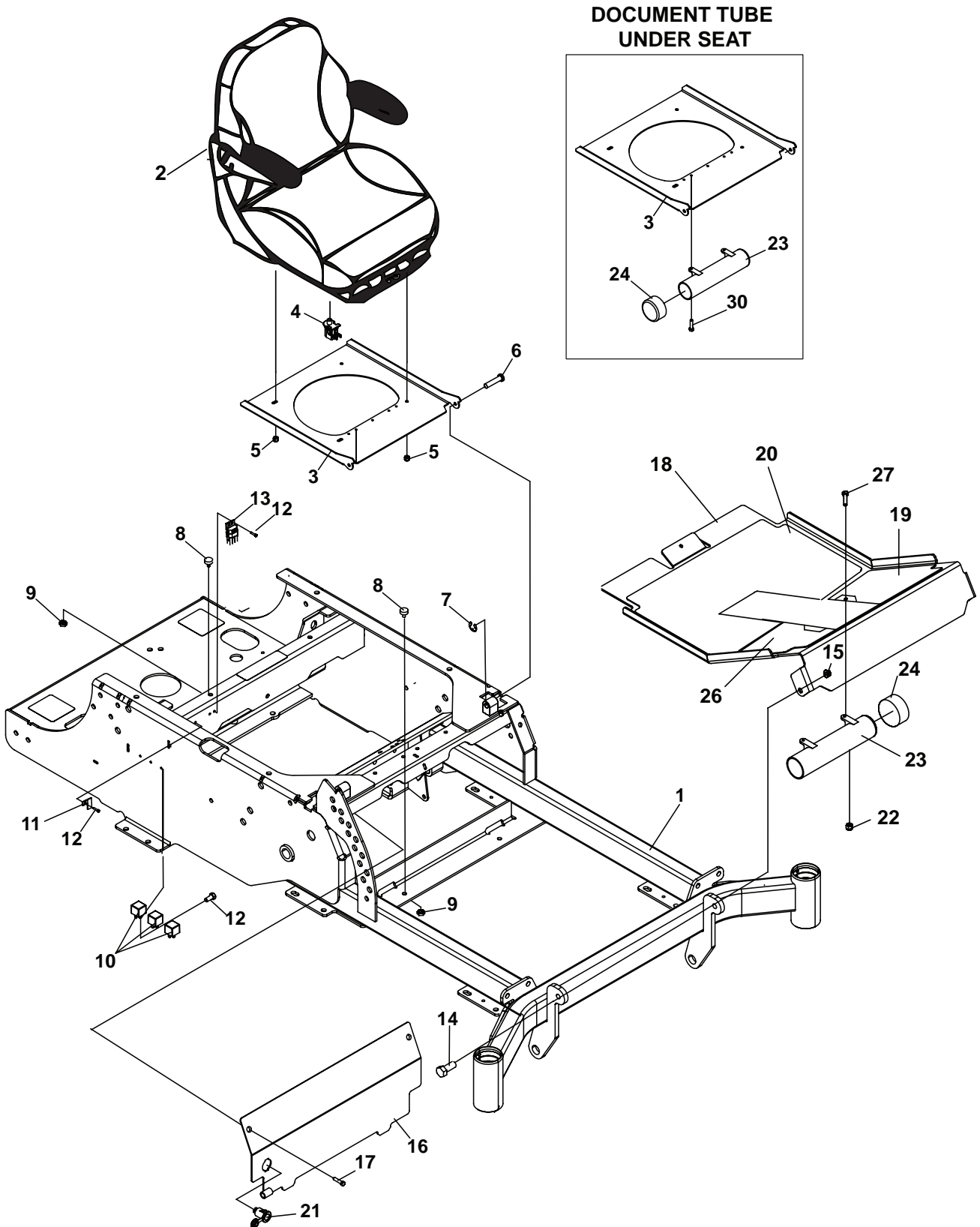

ITM	PART NO.	DESCRIPTION	QTY	ITM	PART NO.	DESCRIPTION	QTY
1	4164049	S-FRAME W/LABS,	1				
2	4163703	SEAT ASSY.	1				
	*4163703-01	SEAT BACK	1				
	*4166863	SEAT BOTTOM	1				
	*4163703-03	ARM REST PAD	2				
	*4163703-04	LH ARM MOUNTING BRKT	1				
	*4163703-05	RH ARM MOUNTING BRKT	1				
3	4163281.7	PLATE-SEAT	1				
4	4124009	SWITCH-SEAT NO	1				
5	64268-02	NUT-NY LOCK 5/16-18	4				
6	33138-09	PIN-CLEVIS GRVD .38 X 1.31	2				
7	64144-30	SNAP RING .375	2				
8	4143354	BUMPER, SEAT MOUNTING	4				
9	64141-6	NUT-5/16-18	4				
10	2722325	RELAY-40AMP SEALED	3				
11	148082-20	FUSE-20 AMP	2				
12	64197-015	BLT-TDFM 10-32X1/2	7				
13	2188154	MODULE-DELAY	1				
14	64123-16	BLT-HEX 3/8-16X1-1/4	2				
15	64229-03	NUT-NYL LOCK 3/8-16	2				
16	4164549.2	PLATE-FRONT REMOVABLE	1				
17	64197-005	BLT-TDFM 3/8-16X1-1/4	2				
18	4167134	S-FOOT PLATE	1				
(INCLUDES ITEMS 19, 20, 22-24, 26 & 27)							
19	4167088	MAT-FOOT PLATE LH UPPER	1				
20	4165931	MAT-FOOT PLATE LOWER	1				
21	4142266	CONNECTOR-12V RECEPT	1				
22	64229-01	NUT-NYLON LOCK 1/4-20	2				
23	4160281	TUBE-DOCUMENT	1				
24	38061A	CAP-VINYL	1				
25	970391	KIT-LIGHT ACCESSORY	1				
26	4167087	MAT-FOOTPLATE RH UPPER	1				
27	64018-2	BLT-CRG 1/4-20X3/4	2				
28	2720975-07	SPACER-NYLON 3/8IN	2				
29	2720975-09	SPACER-NYLON 1/4IN	2				
30	64152-27	1/4-20X5/8 LG SP SCREW	2				

* NOT ILLUSTRATED

STEERING

FastCat Pro

FIGURE 8

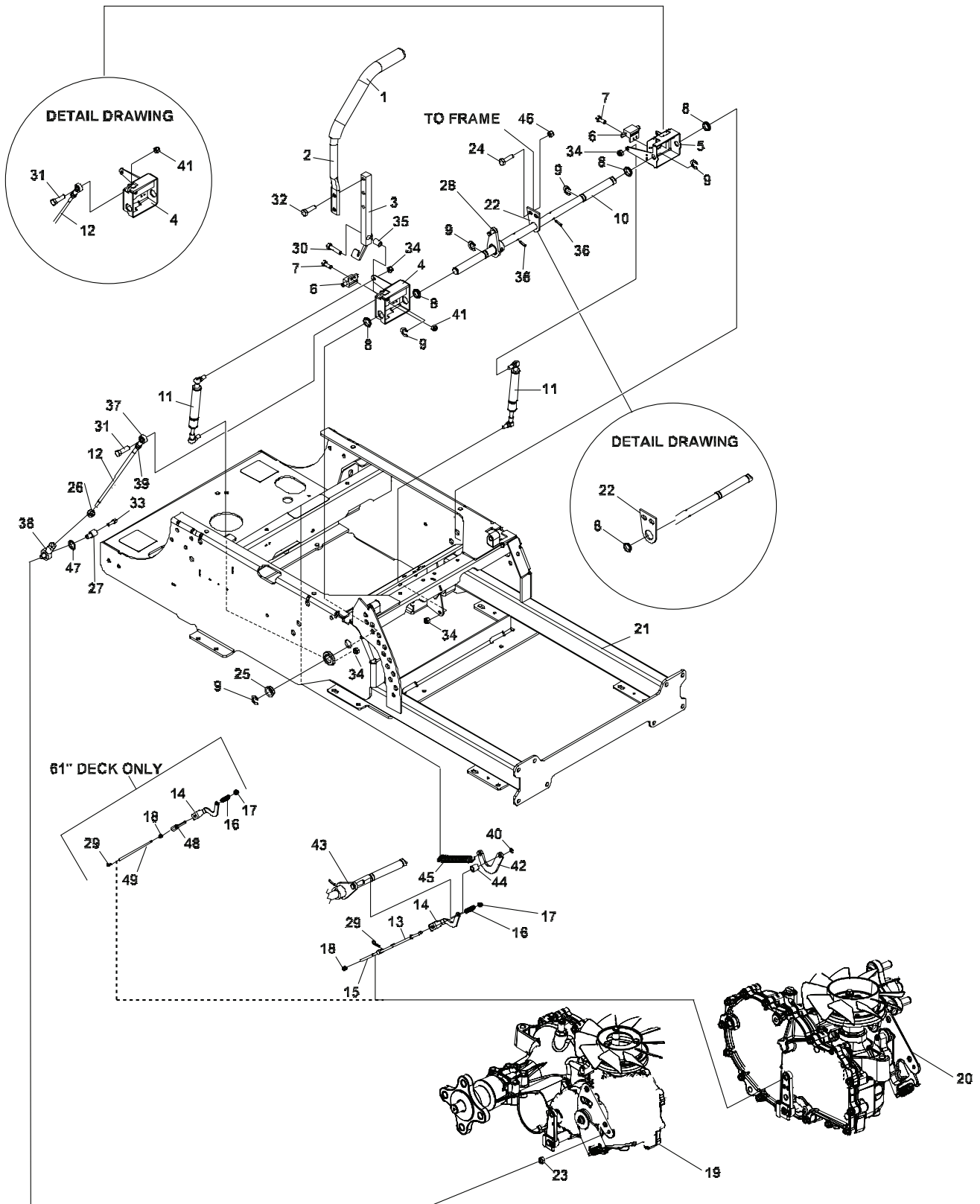

ITM	PART NO.	DESCRIPTION	QTY	ITM	PART NO.	DESCRIPTION	QTY
1	4144705	GRIP-HANDLE	2	30	64123-69	BOLT-5/16-18X1-1/2 HEX	2
2	4156297.7	LEVER-TRACTION CNTRL	2	31	64123-68	BOLT-HEX 5/16-18X1	2
3	4156295	WLDMT-CONTROL BAR, RH	1	32	64123-50	BLT-HEX 3/8-16X1	4
*	4156294	WLDMT-CONTROL BAR, LH	1	33	64123-105	BLT-HEX 1/4-20X1-5/8	2
4	4143673.7	WLDMT-CONTROL BOX RH	1	34	64237-05	LOCKNUT-NYLON M8-1.25	4
5	4143674.7	WLDMT-CONTROL BOX LH	1	35	4133156	SPACER	2
6	108208	SWITCH DBL POLE	2	36	64061-25	ROLL PIN	2
7	64197-015	BLT-TDFM 10-32X1/2 TORX	4	37	4143595-01	ROD END-FEMALE RH	2
8	4127142	BSHG-CONTROL ARM	5	38	4143595-02	ROD END-FEMALE LH	2
9	64221-03	E-RING 19MM/.750	6	39	64025-03	NUT-HEX 5/16-24	2
10	4143676	BAR-CONTROL PIVOT	1	40	64144-30	SNAP RING	2
11	2721246	DAMPENER	2	41	64229-02	LOCKNUT-NYLON 5/16-18	4
12	4143571	ROD-CONTROL	2	42	4147116.7	LINK-BRAKE	1
13	4144525	ROD-PARKING BRAKE	2	43	4155482.7	WLDMT-BRAKE ARM	1
		(USED ON 36", 42", 48" AND 52" ONLY)		44	4147196	SPACER	1
14	4155661.7	LINK-PARKING BRAKE RH	1	45	41-010	SPRING-TENSION	1
*	4155660.7	LINK-PARKING BRAKE LH	1	46	64268-01	NUT-FL NYLON LOCK 1/4-20	2
15	4145589	SWIVEL-3/8-16	2	47	64251-002	WASHER-M6	2
		(USED ON 36", 42", 48" AND 52" ONLY)		48	4164075	WLDMT-ROD PARKING BRAKE	2
16	4155481	SPRING-COMPRESSION	2			(USED ON 61" ONLY)	
17	64268-03	LOCKNUT-NYLON 3/8-16	2	49	4164024	ROD-PARKING BRAKE	2
18	64025-05	NUT-3/8-16 HEX	2			(USED ON 61" ONLY)	
19	4156465	TRANSAXLE-RH	1				
		(USED ON 36", 42", 48", AND 52" ONLY)					
	4163772	TRANSAXLE-RH					
		(USED ON 61" ONLY)					
20	4156464	TRANSAXLE-LH	1				
		(USED ON 36", 42", 48" AND 52" ONLY)					
	4163771	TRANSAXLE-LH					
		(USED ON 61" ONLY)					
21	4164049	S-FRAME W/LABS	1				
22	4146988.7	BRKT-CNTRL BAR SUPT	1				
23	64229-01	LOCKNUT-1/4-20 NYLON	2				
24	64123-89	BOLT-HEX 1/4-20X3/4	2				
25	4146187	BEARING-FLANGE	2				
26	64025-33	NUT-HEX 5/16-24 LH	2				
27	4145106	SPACER-CONTROL ROD	2				
28	4155483.7	BRAKE, ARM LINKAGE	1				
29	64168-2	COTTER-HAIRPIN	2				

* NOT ILLUSTRATED

PARKING BRAKE

FastCat Pro

FIGURE 9

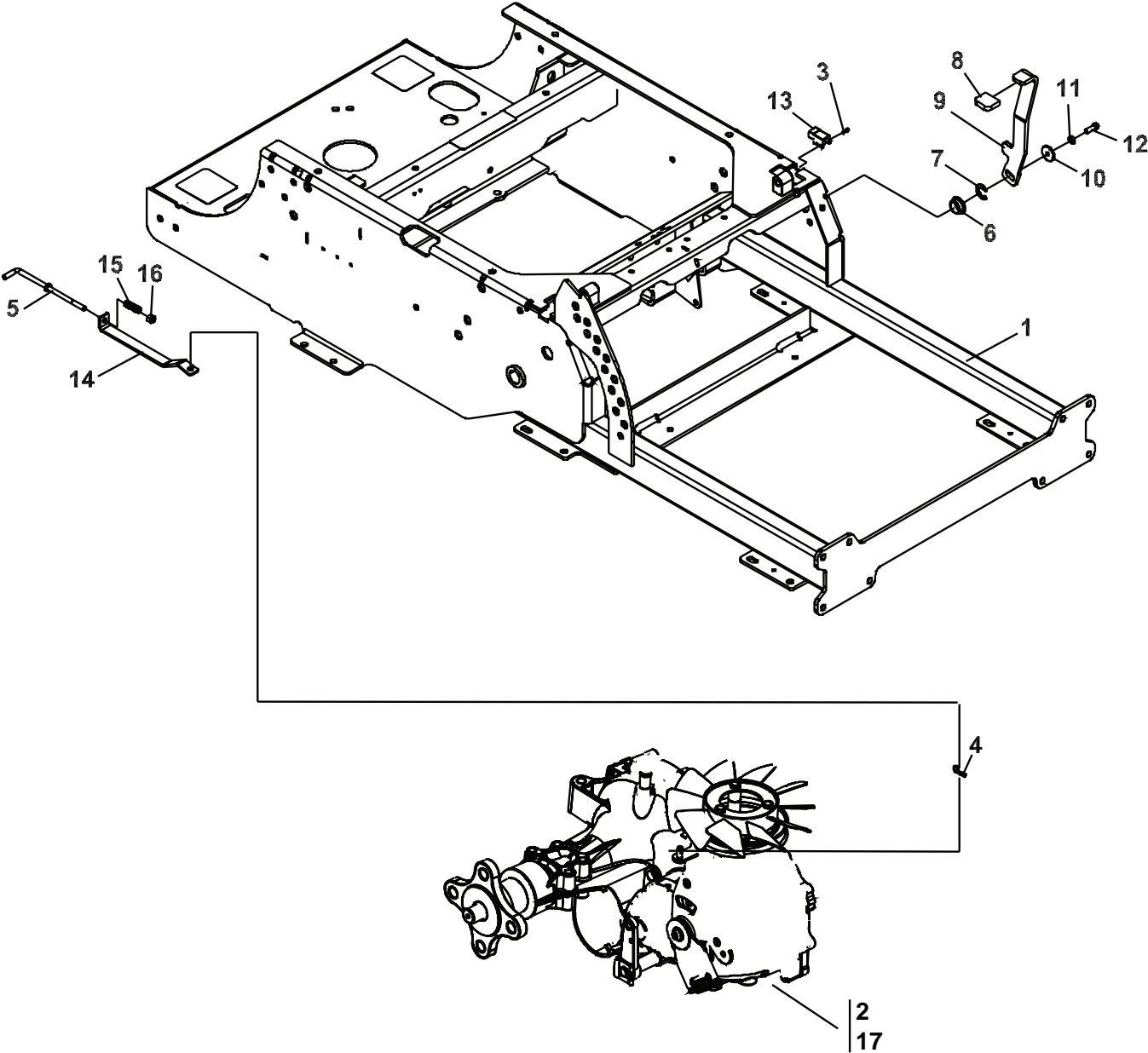

FIGURE 9

ITM	PART NO.	DESCRIPTION	QTY	ITM	PART NO.	DESCRIPTION	QTY
1	4164049	S-FRAME W/LABST	1				
2	4156464	TRANSAXLE, RH (USED ON 36", 42", 48", AND 52" ONLY)	1				
3	64197-015	BLT-TDFM 10-32X1/2 TORX	2				
4	64168-2	COTTER-HAIRPIN.08X1.19	2				
5	4148697	ROD-BYPASS CONTROL	2				
6	4146187	BEARING-FLANGE	1				
7	64221-03	E-RING 19MM/.750	1				
8	2188155	GRIP	1				
9	4163060.7	HANDLE-BRAKE FASTCAT	1				
10	64163-34	WASHER	1				
11	64006-01	LOCKWASHER	1				
12	64123-89	BOLT-HEX 1/4-20X3/4	1				
13	2188156	SWITCH-NONO DBL POLE	1				
14	4148698.7	LINK-DUMP VALVE	2				
15	2720977	SPRING-COMPRESSION	2				
16	64229-01	LOCKNUT-1/4-20 NYLON	2				
17	4163772	TRANSAXLE, RH 61" ONLY	1				

WIRE HARNESS

FastCat Pro

FIGURE 10

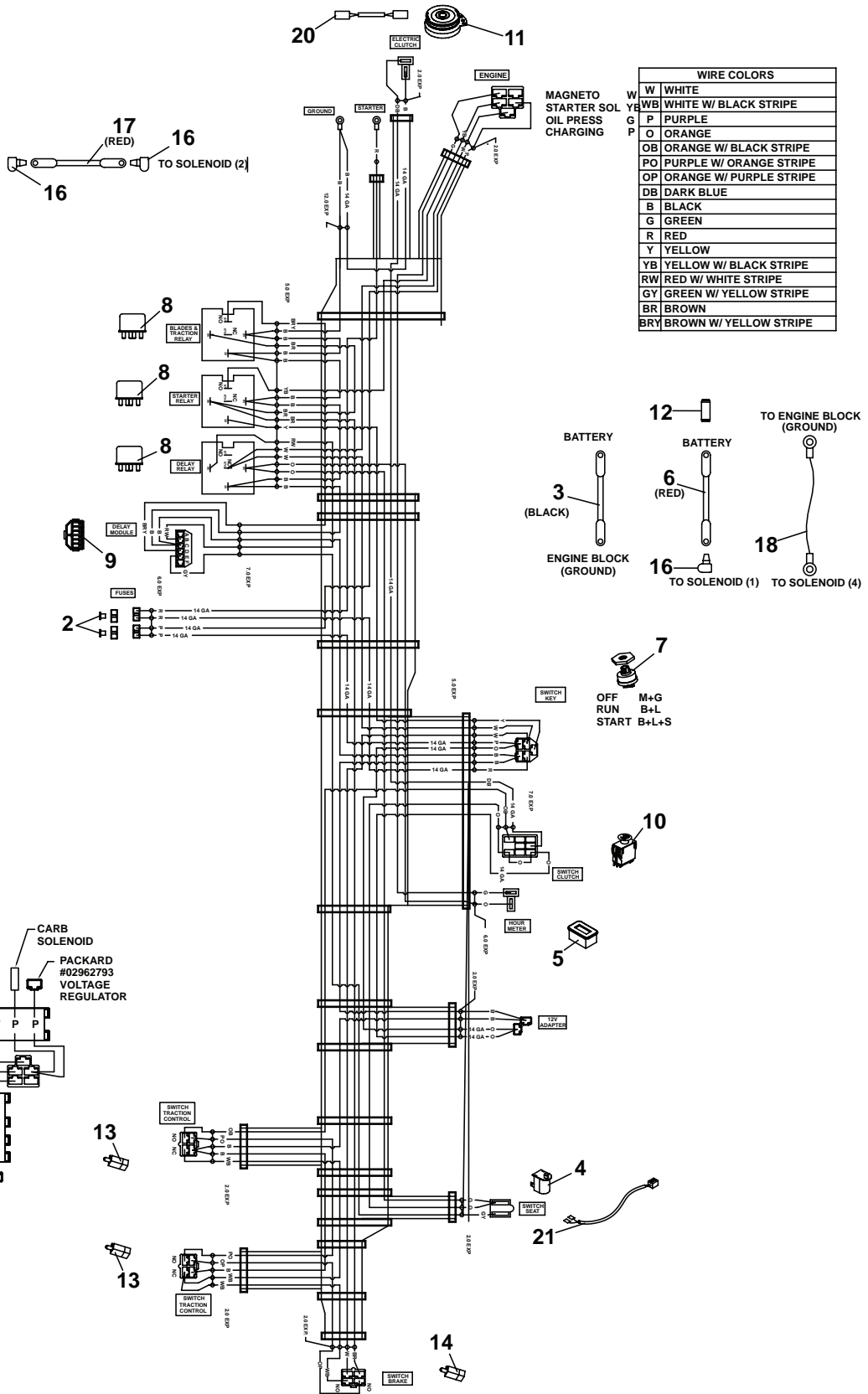
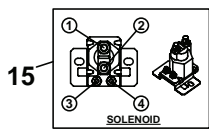

WIRE COLORS	
W	WHITE
WB	WHITE W/ BLACK STRIPE
P	PURPLE
O	ORANGE
OB	ORANGE W/ BLACK STRIPE
PO	PURPLE W/ ORANGE STRIPE
OP	ORANGE W/ PURPLE STRIPE
DB	DARK BLUE
B	BLACK
G	GREEN
R	RED
Y	YELLOW
YB	YELLOW W/ BLACK STRIPE
RW	RED W/ WHITE STRIPE
GY	GREEN W/ YELLOW STRIPE
BR	BROWN
BRY	BROWN W/ YELLOW STRIPE

MAGNETO
STARTER SOL
OIL PRESS
CHARGING

BATTERY
3 (BLACK)
ENGINE BLOCK
(GROUND)

12 BATTERY
6 (RED)
16 TO SOLENOID (1)
18 TO SOLENOID (4)
TO ENGINE BLOCK
(GROUND)

7
OFF M+G
RUN B+L
START B+L+S

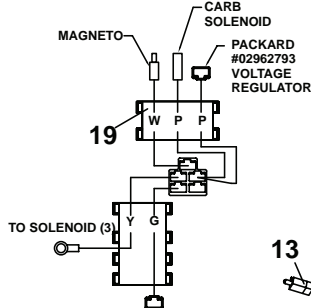

ITM	PART NO.	DESCRIPTION	QTY	ITM	PART NO.	DESCRIPTION	QTY
1	4154880	HARNESS-MAIN WIRE	1				
2	148082-20	FUSE 20 AMP	2				
3	30-419	CABLE-BATT 4 GA BLK 29"	1				
4	4124009	SWITCH-SEAT NO	1				
5	4136792	METER-HOUR	1				
6	30-180	CABLE-BATT 4 GA RED 29"	1				
		(USED ON 942299G, 942404G, 942405G)					
	2722227-02	CABLE-BATTERY W/COND	1				
		(USED ON 942297G, 942298G, 942302G)					
7	128010	SWITCH, KEY	1				
8	2722325	RELAY-40AMP SEALED	3				
9	2188154	MODULE-DELAY	1				
10	2721505	SWITCH-PTO	1				
11	4144116	CLUTCH-ELECTRICAL	1				
12	30-184	COVER-POS TERMINAL	1				
13	108208	SWITCH DBL POLE	2				
14	2188156	SWITCH-NONO DBL POLE	1				
15	38665	SOLENOID	1				
		(USED ON 942299G, 942404G, 942405G)					
16	2308095	COVER-TERMINAL	3				
17	108061-04	CABLE-BATTERY 20 RED	1				
		(USED ON 942299G, 942404G, 942405G)					
18	2188225	WIRE-GROUND	1				
		(USED ON 942299G, 942404G, 942405G)					
19	2188224	HARNESS-JUMPER	1				
		(USED ON 942299G AND 942405G)					
	2722013	HARNESS-JUMPER	1				
		(USED ON 942404G)					
	4164496	HARNESS-JUMPER	1				
		(USED ON 942297G, 942298G, 942302G)					
20	2720949	ASSY-CLUTCH WIRE	1				
21	158136	WIRE-SEAT SWITCH	1				
22*	56-081-36	SLEEVING, ID 0.77 NYLON	1				

* NOT ILLUSTRATED

36" SIDE DISCHARGE

FastCat Pro

FIGURE 11

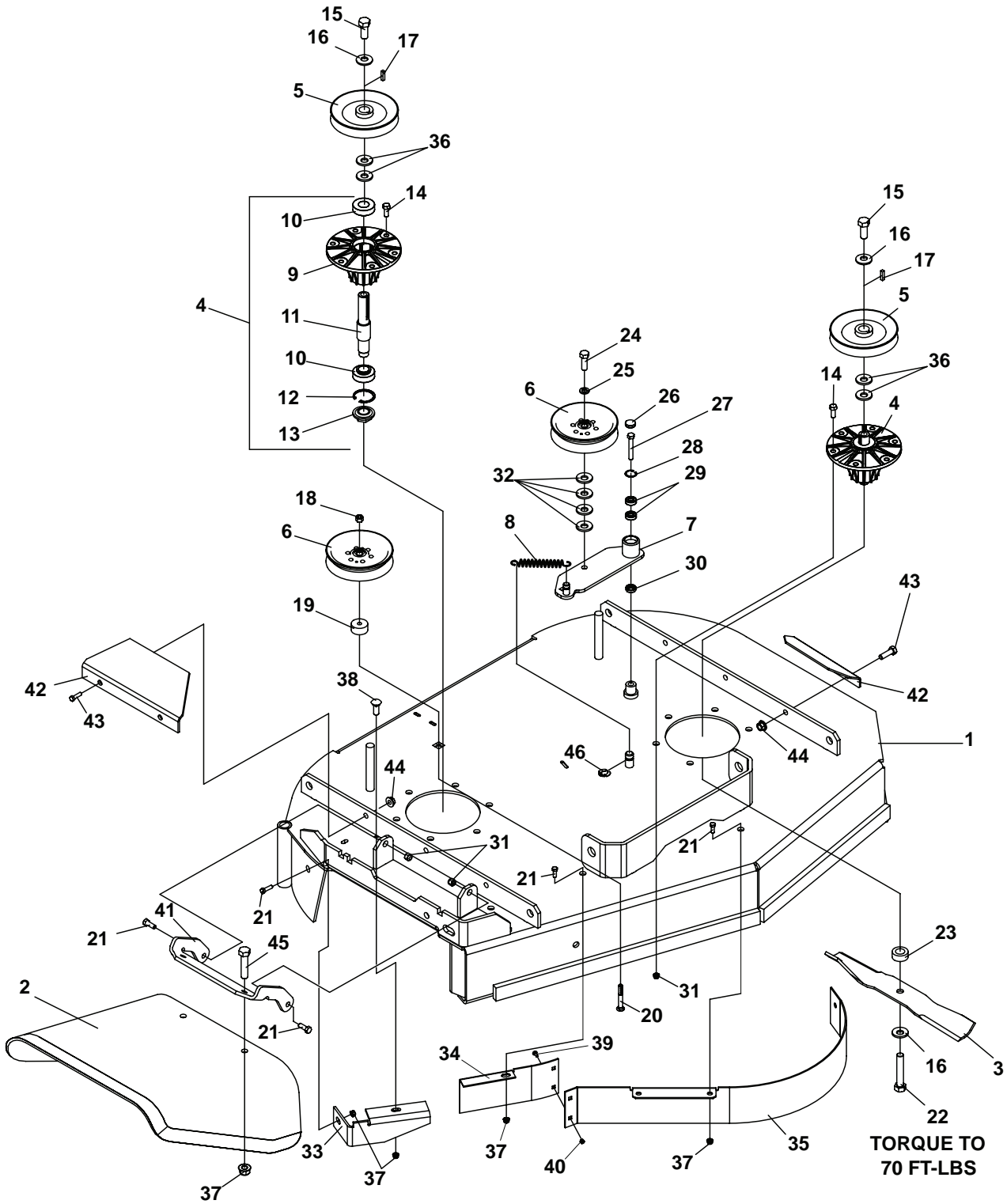

FastCat Pro

FIGURE 11

ITM	PART NO.	DESCRIPTION	QTY	ITM	PART NO.	DESCRIPTION	QTY
1	4146867	S-36 DECK W/LABELS	1	41	4149017.7	HINGE-CHUTE_RUBBER	1
2	4147115	CHUTE-RUBBER	1	42	4147757.7	COVER-BELT 36	2
3	112111-02	BLADE 18.00 OFFST HLFT	2	43	64139-08	BOLT-5/16-18X3/4 WLF	4
4	4165023	S-ASSY SPINDLE OUTER	2	44	64141-6	FLANGE NUT, 5/16-18 NC ZP	4
5	4144947	PULLEY-SPINDLE	2	45	64262-013	BLT-FLG HD 3/8-16 X 1-1/2	2
6	128169	PULLEY, IDLER 5.50	2	46	64144-36	E-CLIP	1
7	4146065	ARM, DECK IDLER ASSY (INCLUDES ITEMS 28-30)	1				
8	2308133	SPRING-EXTENSION	1				
9	4164948	HOUSING-SPINDLE (INCLUDES ITEMS 10 - 13)	2				
10	38348-01	BEARING-SPINDLE SEALED	4				
11	2183070-02	SHAFT-SPINDLE	2				
12	64144-38	SNAP RING	2				
13	38315	NUT-SPINDLE	2				
14	64262-012	BLT-FLG HD 3/8-16 X 1-1/4	12				
15	64123-208	BLT-HEX 5/8-18X1.5	2				
16	64209-03	SPRING WASHER	4				
17	64164-12	KEY-1/4X1/4X1 SQ END	2				
18	64268-05	NUT-FL NYLON LOCK 1/2-13	1				
19	4152578-01	SPACER	1				
20	64123-31	BOLT-1/2-13X3 HEX	1				
21	64123-50	BOLT-HEX 3/8-16X1	7				
22	64123-187	BLT-HEX 5/8-18 X 3 3/4	2				
23	4118314	SPACER-BLADE 16MM	2				
24	64123-90	BOLT, 1/2-20X2 HEX	1				
25	64006-05	LOCKWSHR-HELICAL 1/2	1				
26	4128002	END CAP	1				
27	64270-01	BOLT-MET M10-1.5 X 30	1				
28	64144-40	SNAP RING	1				
29	4128004	BEARING	2				
30	4127999	SEAL	1				
31	64229-03	LOCKNUT-NYLON 3/8-16	14				
32	64163-19	WASHER	4				
33	4115864.7	BAFFLE-DISCHARGE	1				
34	4134343.7	BAFFLE-RIGHT FRONT	1				
35	4147035.7	BAFFLE-FRONT DECK	1				
36	64163-84	WASHER	4				
37	64268-03	NUT-FL NYLON LOCK 3/8-16	8				
38	64018-3	BOLT-3/8-16X1 CARRIAGE	1				
39	64018-2	BLT-CRG 1/4-20X3/4	2				
40	64229-01	LOCKNUT-1/4-20 NYLON	2				

ITM	PART NO.	DESCRIPTION	QTY	ITM	PART NO.	DESCRIPTION	QTY
1	4164884	S-42 DECK W/LABELS	1	41	64163-84	WASHER	4
2	4147399	CHUTE-RUBBER	1	42	64123-208	BLT-HEX 5/8-18X1.5	2
3	4149017.7	HINGE-CHUTE_RUBBER	1	43	64164-12	KEY	2
4	64123-50	BOLT-HEX 3/8-16X1	7	44	4163749.2	LEADING EDGE-ADJ., RH	1
5	64262-013	BLT-FLG HD 3/8-16 X 1-1/2	2	45	4163750.2	LEADING EDGE-ADJ., LH	1
6	64268-03	NUT-FL NYLON LOCK 3/8-16	10	46	64141-4	NUT-WLF 3/8-16	6
7	64229-03	LOCKNUT-NYLON 3/8-16	14	47	64123-50	BOLT-HEX 3/8-16 X 1	6
8	4115864.7	BAFFLE-DISCHARGE	1	48	4152578-01	SPACER	1
9	4150775.7	BAFFLE-FRONT RIGHT	1	49	64268-05	NUT-FL NYLON LOCK 1/2-13	1
10	4150779.7	BAFFLE-FRONT LEFT	1	50	64123-31	BOLT-1/2-13X3 HEX	2
11	64018-2	BLT-CRG 1/4-20X3/4	2	51	64144-36	E-CLIP	1
12	64229-01	LOCKNUT-1/4-20 NYLON	2	52	4163332	ROLLER-ANTI-SCALP	1
13	112111-03	BLADE 21.00 OFFST HLFT	2	53	2721512	ROLLER-5X2.75	1
14	64123-187	BLT-HEX 5/8-18 X 3 3/4	2	54	64123-217	BLT-HEX 3/8-16X4-1/4	1
15	64209-03	SPRING WASHER	4	55	2720685	SPACER-ROLLER	1
16	4118314	SPACER-BLADE 16MM	2	56	64141-13	NUT-WLF 1/2-13	2
17	4152317.7	COVER-BELT	1				
18	4150977.7	COVER-BELT	1				
19	64139-08	BOLT-5/16-18X3/4 WLF	4				
20	64229-02	LOCKNUT-NYLON 5/16-18	4				
21	64141-6	FLANGE NUT, 5/16-18 NC ZP	1				
22	4146065	ARM-DECK IDLER ASSY	1				
		(INCLUDES ITEMS 24-26)					
23	2308133	SPRING	1				
24	64144-40	SNAP RING	1				
25	4128004	BEARING-BALL	2				
26	4127999	SEAL	1				
27	64270-01	BOLT-MET HEX M10-1.5X30	1				
28	4128002	END CAP	1				
29	128169	PULLEY-IDLER 5.50	2				
30	64123-90	BOLT-1/2-20X2 HEX	2				
31	64006-05	LOCKWSHR-HELICAL 1/2	2				
32	64163-19	WASHER	4				
33	4149197	PULLEY-6.25 DEEP GRVE	2				
34	4165023	S-ASSY SPINDLE OUTER	2				
		(INCLUDES ITEMS 36-39)					
35	4164948	HOUSING-SPINDLE	2				
36	38348-01	BEARING-SPINDLE	4				
37	2183070-02	SHAFT-SPINDLE	2				
38	64144-38	SNAP RING	2				
39	38315	NUT-SPINDLE	2				
40	64262-012	BLT-FLG HD 3/8-16 X 1-1/4	12				

ITM	PART NO.	DESCRIPTION	QTY	ITM	PART NO.	DESCRIPTION	QTY
1	4146864	S-48 DECK W/LABELS	1	41	4165971.7	BAFFLE-FRONT LH	1
2	4146596.2	GUARD-LH 48" DECK	1	42	4165972.7	BAFFLE-FRONT CENTER	1
3	4146595.2	GUARD-RH 48" DECK	1	43	4165973.7	BAFFLE-RIGHT FRONT	1
4	4147115	CHUTE-RUBBER	1	44	4120208.7	BAFFLE-DISCHARGE	1
5	64123-50	BOLT-HEX 3/8-16X1	9	45	64018-3	BOLT-3/8-16X1 CARRIAGE	1
6	64018-11	BOLT-CRG 1/2-13X3LG	2	46	64268-03	NUT-FL NYLON LOCK 3/8-16	10
7	64229-03	LOCKNUT-NYLON 3/8-16	25	47	64018-2	BLT-CRG 1/4-20X3/4	7
8	64205-029	BLT-MET M12X1.75X40	8	48	64229-01	LOCKNUT-1/4-20 NYLON	7
9	64246-04	NUT-WHIZ M12-1.75	16	49	64163-84	WASHER	6
10	2188127	CHAIN-6.35 (.250) 5 LINKS	4	50	64163-19	WASHER	A/R
11	4144947	PULLEY-SPINDLE	3	51	38524	KNOB-4 PRONG	2
12	112111-01	BLADE 16.25 OFFST HLFT	3	52	4149017.7	HINGE-CHUTE_RUBBER	1
13	64262-012	BLT-FLG HD 3/8-16 X 1-1/4	18	53	64144-36	E-CLIP	1
14	64209-03	SPRING WASHER.67 ID	6	54	4163332	ROLLER-ANTI SCALP	2
15	64164-12	KEY-1/4X1/4X1 SQ END	3	55	64141-13	NUT WLF 1/2-13	4
16	128169	PULLEY, IDLER 5.50	3	56	64123-31	BLT-HEX 1/2-13X3	2
17	4147896	ARM-DECK IDLER ASSY (INCLUDES ITEMS 30-32)	1	57	4163514.7	GUIDE-BELT	1
				58	4165955.7	BRKT-BAFFLE MNTG	3
18	4165023	S-ASSY SPINDLE OUTER (INCLUDES ITEMS 25-29)	3				
19	64006-05	LOCKWSHR-HELICAL 1/2	1				
20	64123-05	BLT-HEX 1/2-20X1-1/2	1				
21	4118314	SPACER-BLADE 16MM	3				
22	64123-187	BLT-HEX 5/8-18 X 3 3/4	3				
23	64123-208	BLT-HEX 5/8-18X1.5	3				
24	2308133	SPRING-EXTENSION	1				
25	38348-01	BEARING-SPINDLE SEALED	6				
26	4164948	HOUSING-SPINDLE 6 HOLE	3				
27	64144-38	SNAP RING	3				
28	38315	NUT-SPINDLE	3				
29	2183070-02	SHAFT-SPINDLE	3				
30	4127999	SEAL	1				
31	4128004	BEARING	2				
32	64144-40	SNAP RING	1				
33	64270-01	BOLT-MET M10-1.5 X 30	1				
34	4128002	END CAP	1				
35	4152578-01	SPACER	1				
36	64262-013	BLT-FLG HD 3/8-16 X 1-1/2	2				
37	64268-05	NUT-FL NY LOCK 1/2-13	2				
38	64018-30	BOLT-CARRIAGE	1				
39	2721512	ROLLER	1				
40	2720685	SPACER-ROLLER	1				

ITM	PART NO.	DESCRIPTION	QTY	ITM	PART NO.	DESCRIPTION	QTY
1	4153817	S-52 DECK W/LABELS	1	41	4165965.7	BAFFLE-FRONT LH	1
2	4143552.2	GUARD-LH 52" DECK	1	42	4165966.7	BAFFLE-FRONT CENTER	1
3	4143553.2	GUARD-RH 52" DECK	1	43	4165967.7	BAFFLE-RIGHT FRONT	1
4	4147115	CHUTE-RUBBER ASSY	1	44	4115864.7	BAFFLE-DISCHARGE	1
5	64123-50	BOLT-HEX 3/8-16X1	9	45	64018-3	BOLT-3/8-16X1 CARRIAGE	1
6	64018-11	BOLT-CRG 1/2-13X3LG	2	46	64268-03	NUT-FL NYLON LOCK 3/8-16	10
7	64229-03	LOCKNUT-NYLON 3/8-16	24	47	64018-2	BLT-CRG 1/4-20 X 3/4	4
8	64205-029	BLT-MET M12X1.75X40	8	48	64229-01	LOCKNUT-1/4-20 NYLON	4
9	64246-04	NUT-WHIZ M12-1.75	16	49	64163-84	WASHER	6
10	2188127	CHAIN-6.35 (.250) 5 LINKS	4	50	64163-19	WASHER	A/R
11	4144947	PULLEY-SPINDLE	3	51	38524	KNOB-4 PRONG	2
12	112111-02	BLADE 18.00 OFFST HLFT	3	52	4149017.7	HINGE-CHUTE_RUBBER	1
13	64262-012	BLT-FLG HD 3/8-16 X 1-1/4	18	53	64144-36	E-CLIP	1
14	64209-03	SPRING WASHER.67 ID	6	54	4163514.7	GUIDE-BELT	1
15	64164-12	KEY-1/4X1/4X1 SQ END	3	55	4165955.7	BRKT-BAFFLE MOUNTING	2
16	128169	PULLEY, IDLER 5.50	3	56	4165870.7	BRKT-BAFFLE MOUNTING	1
17	4147896	ARM-DECK IDLER ASSY	1				
		(INCLUDES ITEMS 30-32)					
18	4165023	S-ASSY SPINDLE OUTER	3				
		(INCLUDES ITEMS 25-29)					
19	64006-05	LOCKWSHR-HELICAL 1/2	1				
20	64123-90	BLT-HEX 1/2-20 X 2	1				
21	4118314	SPACER-BLADE 16MM	3				
22	64123-187	BLT-HEX 5/8-18 X 3 3/4	3				
23	64123-208	BLT-HEX 5/8-18X1.5	3				
24	2308133	SPRING-EXTENSION	1				
25	38348-01	BEARING-SPINDLE SEALED	6				
26	4164948	HOUSING-SPINDLE 6 HOLE	3				
27	64144-38	SNAP RING	3				
28	38315	NUT-SPINDLE	3				
29	2183070-02	SHAFT-SPINDLE	3				
30	4127999	SEAL	1				
31	4128004	BEARING	2				
32	64144-40	SNAP RING	1				
33	64270-01	BOLT-MET M10-1.5 X 30	1				
34	4128002	END CAP	1				
35	4152578-01	SPACER	1				
36	64262-013	BLT-FLG HD 3/8-16 X 1-1/2	2				
37	64268-05	NUT-FL NY LOCK 1/2-13	2				
38	64018-30	BOLT-CRG 3/8-16 X 4-1/2	3				
39	2721512	ROLLER	3				
40	2720685	SPACER-ROLLER	3				

61" SIDE DISCHARGE

FastCat Pro

FIGURE 15

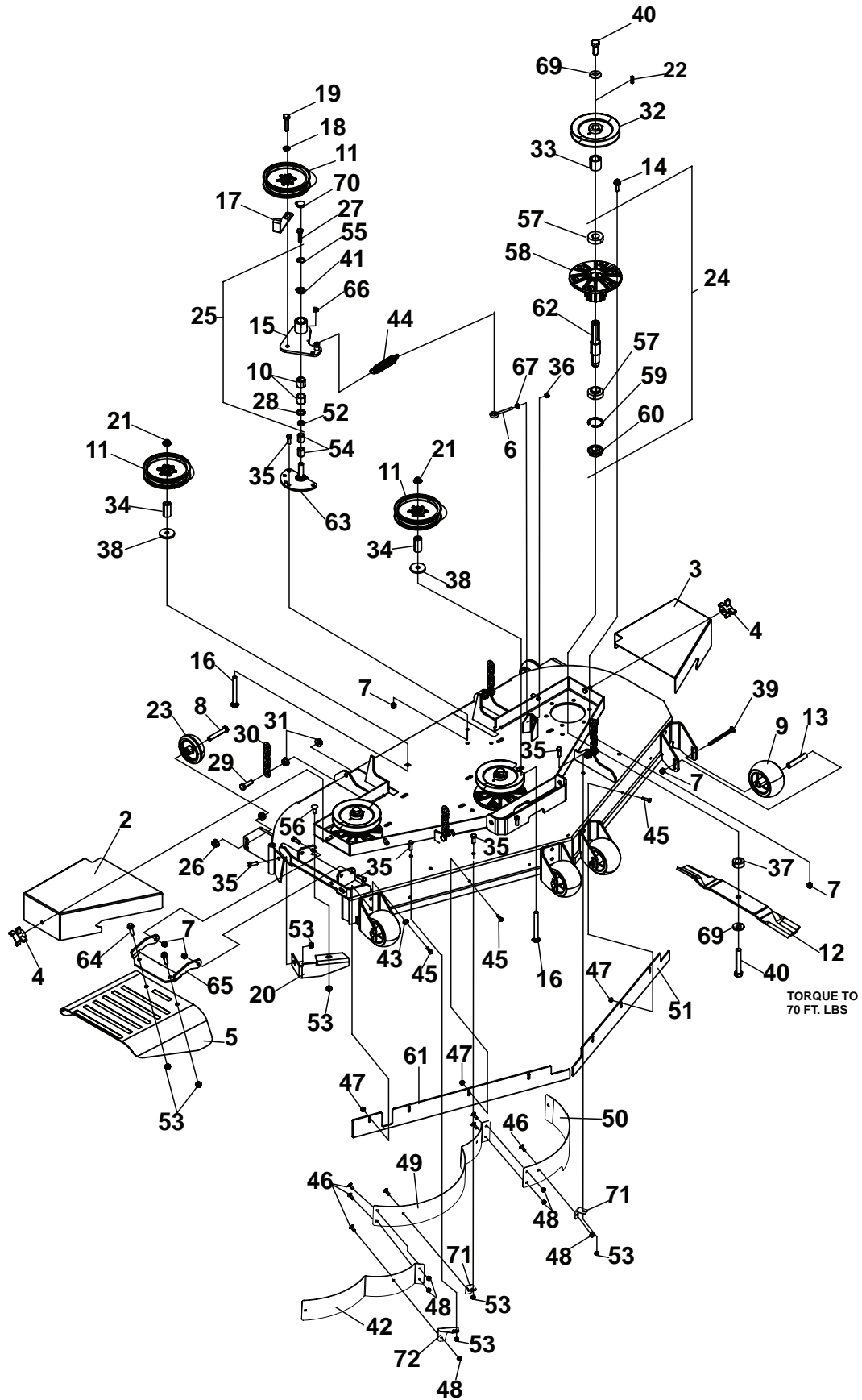

ITM	PART NO.	DESCRIPTION	QTY	ITM	PART NO.	DESCRIPTION	QTY
1	4164130	S-61" DECK	1	43	64163-55	WSHR .328X.75X14 GA	1
2	4163809.2	BELT COVER RH	1	44	4163586	SPRING-EXTENSION	1
3	4163808.2	BELT COVER LH	1	45	64123-114	BLT-HEX 1/4-20X1	7
4	38524	KNOB-4 PRONG 3/8-16	2	46	64018-2	BLT-CRG 1/4-20X3/4	4
5	4147399	CHUTE-RUBBER ASSY	1	47	64141-2	NUT-WLF 1/4-20	7
6	64158-08	EYE BOLT	1	48	64229-01	LOCKNUT-1/4-20 NYLON	4
7	64229-03	LOCKNUT NYLON 3/8-16	28	49	4165969.7	BAFFLE-FRONT CTR 61	1
8	64123-31	BLT-HEX 1/2-13X3	2	50	4165968.7	BAFFLE-FRONT LH	1
9	2721512	ROLLER-5X2.75 CENTERED	5	51	4163441.7	EXTENSION-61IN, LH	1
10	548138	BRG NDL88 1.12 1.00 OPEN END	2	52	4163014	SPACER	1
11	128169	PULLEY IDLER 5.50	3	53	64268-03	NUT-FL NYLN LOCK 3/8-16	10
12	112111-03	BLADE 21.00 OFFST HLFT	3	54	4163155	INNER RING	2
13	2720685	SPACER-ROLLER	5	55	64144-40	SNAP RING	1
14	64262-012	BLT-FLG HD 3/8-16 X 1-1/4	18	56	64018-3	BOLT-3/8-16X1 CARRIAGE	1
15	4164094.7	WLDMT-IDLER ARM	1	57	38348-01	BEARING-SPINDLE SEALED	6
16	64018-33	BLT-CRG 1/2-13 X 4-1/2	2	58	4164948	HOUSING-SPINDLE 6 HOLE	3
17	4163514.7	GUIDE-BELT	1	59	64144-38	SNAP RING	3
18	64006-05	LOCKWSHR-1/2 HELICAL	1	60	38315	NUT-SPINDLE	3
19	64123-90	BLT-HEX 1/2-20X2	1	61	4163440.7	EXTENSION-61IN, RH	1
20	4115864.7	BAFFLE-DISCHARGE	1	62	2183070-01	SHAFT-SPINDLE LONG	3
21	64268-05	NUT-FL NYLON LOCK 1/2-13	2	63	4163030.7	WLDMT-IDLER PIN	1
22	64164-12	1/4X1/4X1 SQ END KEY	3	64	64262-013	BLT-FLG HD 3/8-16 X 1-1/2	2
23	4163332	ROLLER, ANTI-SCALP	2	65	4149017.7	HINGE-CHUTE RUBBER	1
24	4165022	S-ASSYSPNDL ZT200 CNTR (INCLUDES ITEMS 57-60, & 62)	3	66	85010N	ZERK-1/4-28 STR SLF THRD	1
25	4164095	ASSY-IDLER ARM (INCLUDES ITEMS 10, 15, 28, 41, 55, 66)	1	67	64141-6	NUT-WLF 5/16-18	1
26	64141-13	NUT-WLF 3/8-24	4	68*	64123-217	BLT-HEX 3/8-16X4 - 1/4 (USED ON REAR CENTER ANTI-SCALP ROLLER)	1
27	64270-02	BOLT-HEX M10-1.5X30 ISOCL109	1	69	64209-03	SPRING WASHER .67 ID	6
28	521438	GREASE SEAL	1	70	4128002	END CAP- 26X7	4
29	64205-029	BLT-METRIC M12X1.75X40	4	71	4165955.7	BRKT-BAFFLE MNTG	2
30	2188127	CHAIN-6.35 (.250) 5 LINKS	4	72	4165871.7	BRKT-BAFFLE MNTNG, RH	1
31	64246-04	NUT-WHIZ M12-1.75	8				
32	4149197	PULLEY-SPINDLE	3				
33	4163804	SPACER-1.015X1.75X1.50	3				
34	4163802	SPACER-1.0X.516X1-15/16	2				
35	64123-50	BOLT-HEX 3/8-16X1	12				
36	64229-02	LOCKNUT-NYLON 5/18	1				
37	4118314	SPACER-BLADE 16MM	3				
38	64163-74	WSHR-.516X2X.25THK PLT	2				
39	64018-30	BLT-CRG 3/8-16 X 4-1/2	4				
40	64123-208	BLT-HEX 5/8-18X1.5	3				
41	4128004	BEARING	1				
42	4165970.7	BAFFLE-RIGHT FRONT	1				

*NOT ILLUSTRATED

FIGURE 16

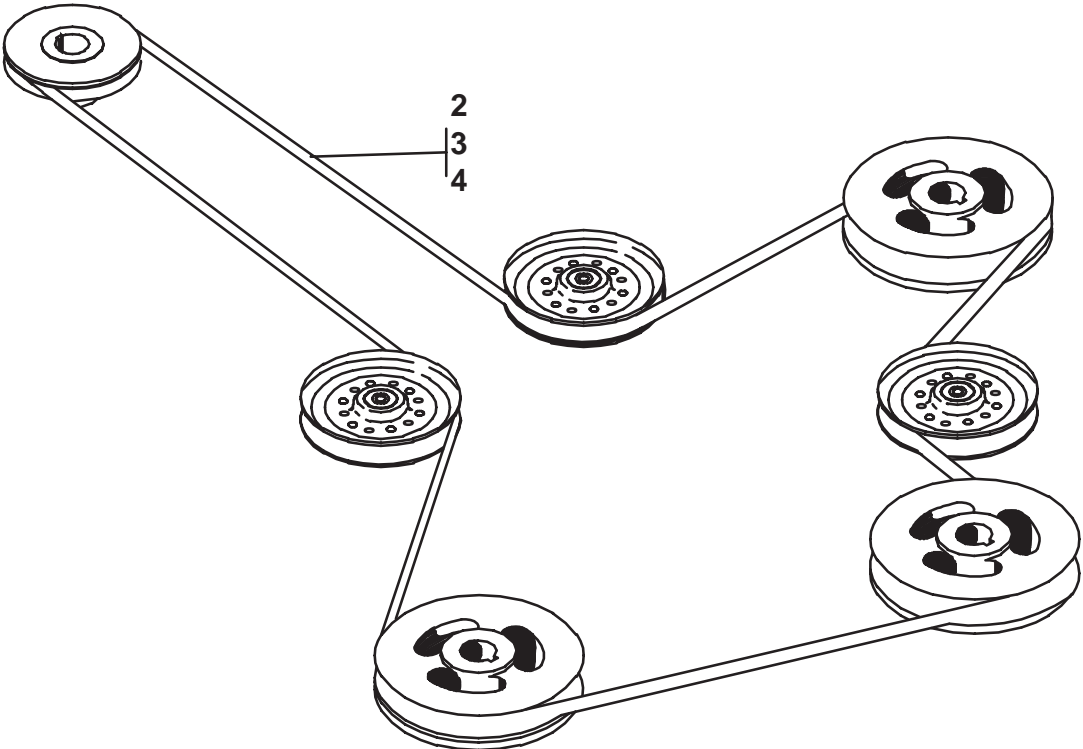
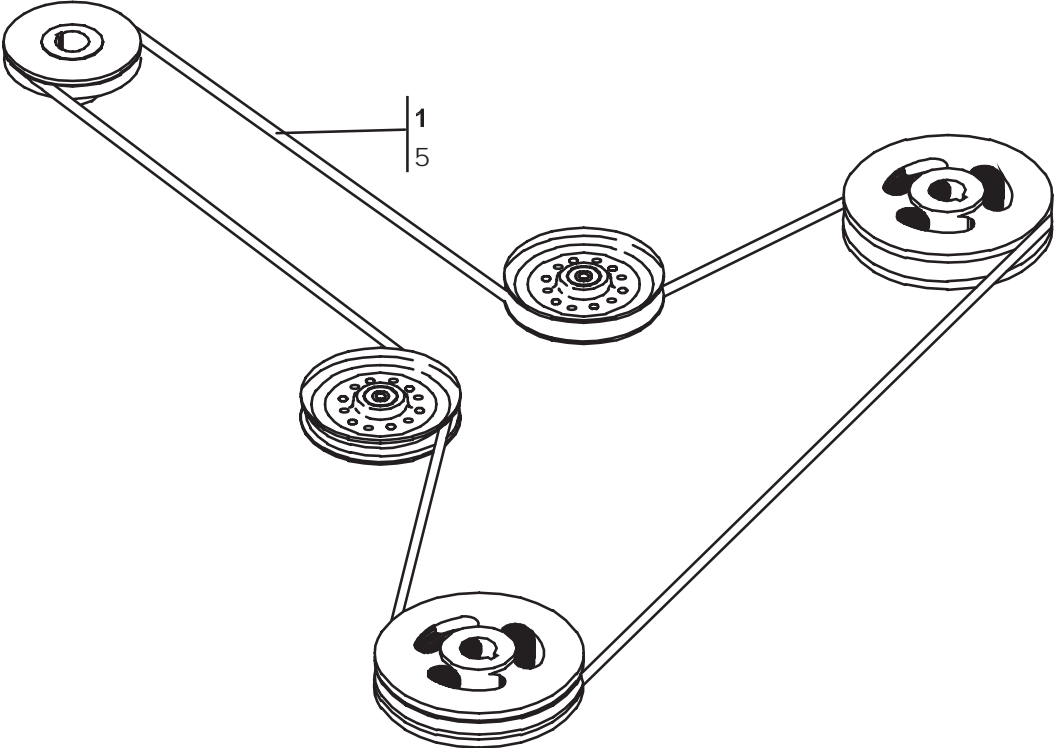
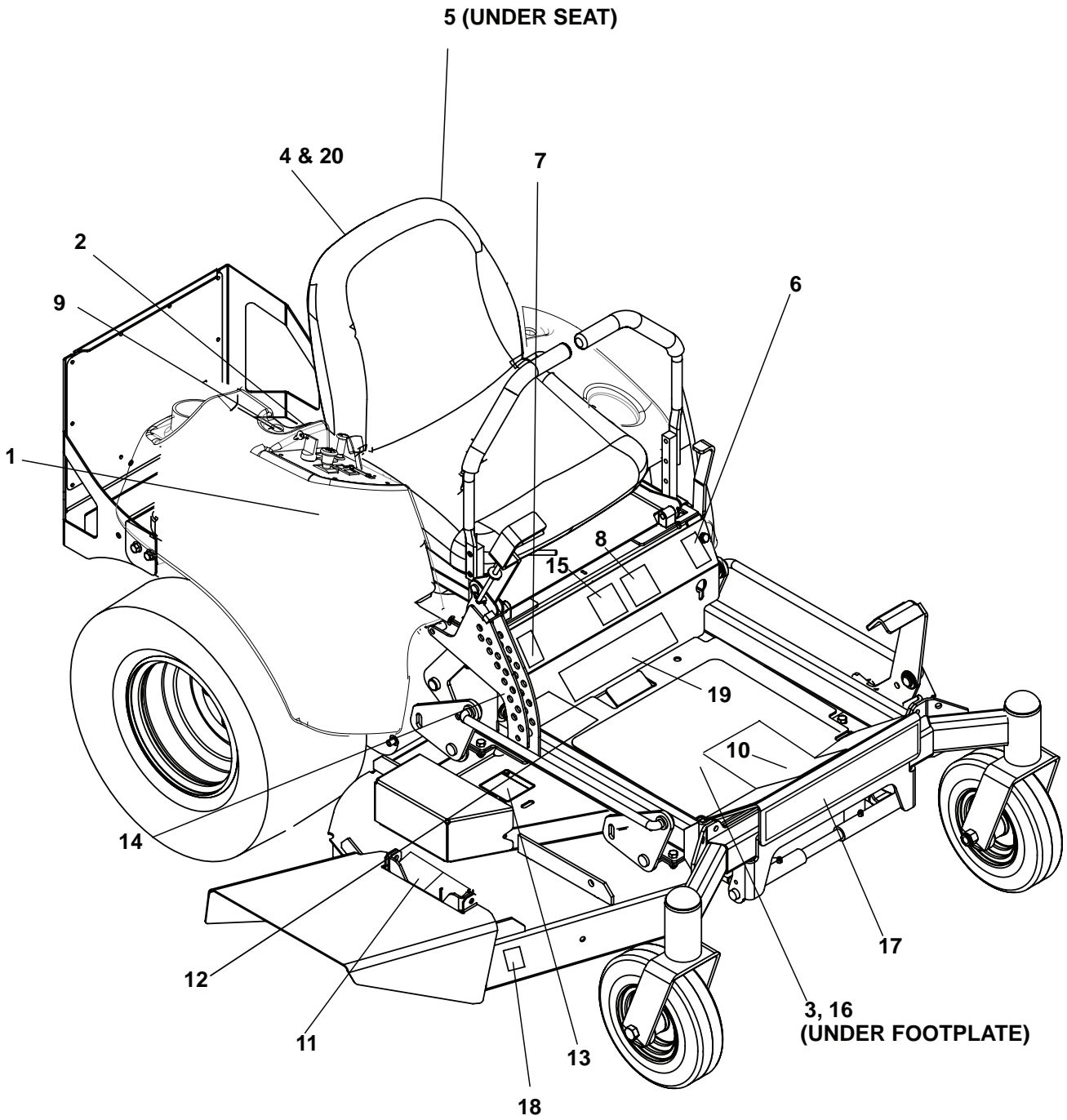

FIGURE 16

ITM	PART NO.	DESCRIPTION	QTY	ITM	PART NO.	DESCRIPTION	QTY
1	4144212	BELT-36" CUTTERDECK	1				
2	4143733	BELT-52" CUTTERDECK	1				
3	4147095	BELT-48" CUTTERDECK	1				
4	4163569	BELT-61" CUTTERDECK	1				
5	4147716	BELT-42" CUTTERDECK	1				

FIGURE 17



ITM	PART NO.	DESCRIPTION	QTY	ITM	PART NO.	DESCRIPTION	QTY
1	4165662	LABEL-CONTROL PANEL	1				
2	2000570	LABEL-WARN FUEL PICT.	2				
3	4164525	LABEL-INFORMATION	1				
4	4158400	LABEL-BOBCAT	2				
5	2000590	LABEL-WARN BATTERY	1				
6	4165616	LABEL-LH TRACTION	1				
7	4165615	LABEL-RH TRACTION	1				
8	4126804	LABEL-PARKING BRAKE	1				
9	4147617	LABEL-FUEL TANK VALVE	1				
10	4165610	LABEL-WARNING	1				
11	4164269	LABEL-DANGER/WARNING	2				
12	2720743	LABEL-HOC INNER	1				
13	2000577	LABEL, WARNING	3				
14	4126611	LABEL-HOC OUTER	1				
15	4146936	LABEL-MAN LOC SEAT	1				
	4165730	LABEL-MAN LOC FOOTPLATE					
16	4133980	LABEL-MAINTENANCE	2				
17	4164406	LABEL-BOB-CAT	1				
18	4162916	LABEL-DECK SIZE 61"	1				
	4162915	LABEL-DECK SIZE 52"					
	4162914	LABEL-DECK SIZE 48"					
	4162913	LABEL-DECK SIZE 42"					
	4162912	LABEL-DECK SIZE 36"					
19	4164765	LABEL-FASTCAT PRO	1				
20	4116761	LABEL-MADE IN USA	1				

SCHILLER GROUNDS CARE, INC.
ONE BOB-CAT LANE
P.O. BOX 469
JOHNSON CREEK, WI 53038
920-699-2000
www.schillergc.com



©Schiller Grounds Care, Inc. 2010