

BOB-CAT[®]

PARTS MANUAL

LEO

Models:

942280 BOBCAT LEO-17HP 48 SD
942281 BOBCAT LEO-18HP 52 SD
942282 BOBCAT LEO-25HPI 52 SD



WARNING: If incorrectly used this machine can cause severe injury. Those who use and maintain this machine should be trained in its proper use, warned of its dangers and should read the entire manual before attempting to set up, operate, adjust or service the machine.

Operation & Safety Manual: 4125725



4125724 REV C

**CALIFORNIA
Proposition 65 Warning**

Diesel engine exhaust and some of its constituents are known to the State of California to cause cancer, birth defects and other reproductive harm.

 **WARNING**

The engine exhaust from this product contains chemicals known to the State of California to cause cancer, birth defects or other reproductive harm.

**Californie Proposition 65
Avertissement**

Les échappements des moteurs diesel et certains de leurs composés sont reconnus par l'Etat de Californie pour être cancérigènes, provoquer des défauts congénitaux et d'autres dangers en matière de reproduction.

 **AVERTISSEMENT**

L'émission du moteur de ce matériel contient des produits chimiques que l'Etat de Californie considère être cancérigènes, provoquer des défauts congénitaux et d'autres dangers en matière de reproduction.

**California Advertencia
de la Proposicion 65**

El estado de California hace saber que los gases de escape de los motores diesel y algunos de sus componentes producen cáncer, defectos de nacimiento y otros daños en el proceso de reproducción humana.

 **ADVERTENCIA**

El estado de California hace saber que los gases de escape de este producto contienen productos químicos que producen cáncer, defectos de nacimiento y otros daños en el proceso de reproducción humana.

IMPORTANT MESSAGE

Thank you for purchasing this Bob-Cat product. You have purchased a world class mowing product, one of the best designed and built anywhere.

This machine comes with an Operation and Safety Manual. The useful life and good service you receive from this machine depends to a large extent on how well you read and understand these manuals. Treat your machine properly, lubricate and adjust it as instructed, and it will give you many years of reliable service.

Your safe use of this Bob-Cat product is one of our prime design objectives. Many safety features are built in, but we also rely on your good sense and care to achieve accident-free operation. For best protection, study the manual thoroughly. Learn the proper operation of all controls. Observe all safety precautions. Follow all instructions and warnings. Do not remove or defeat any safety features. Make sure those who operate this machine are as well informed and careful in its use as you are.

See a Bob-Cat dealer for any service or parts needed. Bob-Cat service ensures that you continue to receive the best results possible from Bob-Cat's products. You can trust Bob-Cat replacement parts because they are manufactured with the same high precision and quality as the original parts.

Bob-Cat designs and builds its equipment to serve many years in a safe and productive manner. For longest life, use this machine only as directed in the manuals, keep it in good repair and follow safety warnings and instructions. You'll always be glad you did.

Jacobsen, a Textron Company
One Bob Cat Lane
Johnson Creek, WI 53038-0469

TABLE OF CONTENTS	FIGURES	PAGE
SAFETY		2
PART SECTION		3
FRAME-ENGINE/CLUTCH ASSY	FIGURE 1	4, 5
FUEL TANK/BUMPER & CONTROL PANEL	FIGURE 2	6, 7
DECK LIFT ASSEMBLY	FIGURE 3	8, 9
CASTER ASSEMBLY	FIGURE 4	10, 11
SEAT ASSEMBLY	FIGURE 5	12, 13
STEERING	FIGURE 6	14, 15
WIRE HARNESS	FIGURE 7	16, 17
DECK LIFT/REAR WHEEL	FIGURE 8	18, 19
KICKPLATE ASSEMBLY	FIGURE 9	20, 21
48" SIDE DISCHARGE	FIGURE 10	22, 23
52" SIDE DISCHARGE	FIGURE 11	24, 25
BELTS-CUTTERDECK	FIGURE 12	26, 27
DECALS-POWERUNIT	FIGURE 13	28, 29

NOTICE !!!

Unauthorized modifications may present **extreme** safety hazards to operators and bystanders and could also result in product damage.

Jacobsen, a Textron Company strongly warns against, rejects and disclaims any modifications, add-on accessories or product alterations that are not designed, developed, tested and approved by Jacobsen Engineering Department. Any Jacobsen product that is altered, modified or changed in any manner not specifically authorized after original manufacture—including the addition of “after-market” accessories or component parts not specifically approved by Jacobsen—will result in the Jacobsen Warranty being voided.

Any and all liability for personal injury and/or property damage caused by any unauthorized modifications, add-on accessories or products not approved by Jacobsen will be considered the responsibility of the individual(s) or company designing and/or making such changes. Jacobsen will vigorously pursue full indemnification and costs from any party responsible for such unauthorized post-manufacture modifications and/or accessories should personal injury and/or property damage result.



This symbol means:
ATTENTION!
BECOME ALERT!

Your safety and the safety of others is involved.

Signal word definitions:

The signal words below are used to identify levels of hazard seriousness. These words appear in this manual and on the safety labels attached to Bob-Cat machines. For your safety and the safety of others, read and follow the information given with these signal words and/or the symbol shown above.



DANGER indicates an imminently hazardous situation which, if not avoided, **WILL** result in death or serious injury.



WARNING indicates a potentially hazardous situation which, if not avoided, **COULD** result in death or serious injury.



CAUTION indicates a potentially hazardous situation which, if not avoided, **MAY** result in minor or moderate injury. It may also be used to alert against unsafe practices or property damage.



CAUTION used without the safety alert symbol indicates a potentially hazardous situation which, if not avoided, **MAY** result in property damage

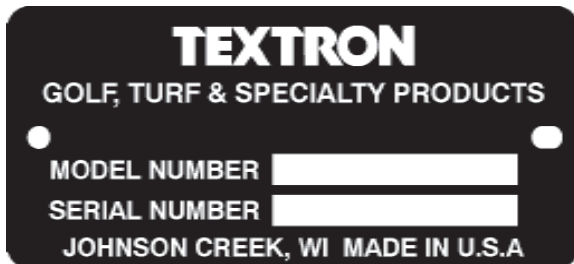

MODEL NUMBER: This number appears on sales literature, technical manuals and price lists.

SERIAL NUMBER: This number appears only on your mower. It contains the model number followed consecutively by the serial number. Use this number when ordering parts or seeking warranty information.

PARTS SECTION

FRAME-ENGINE/CLUTCH ASSY

LEO

FIGURE 1

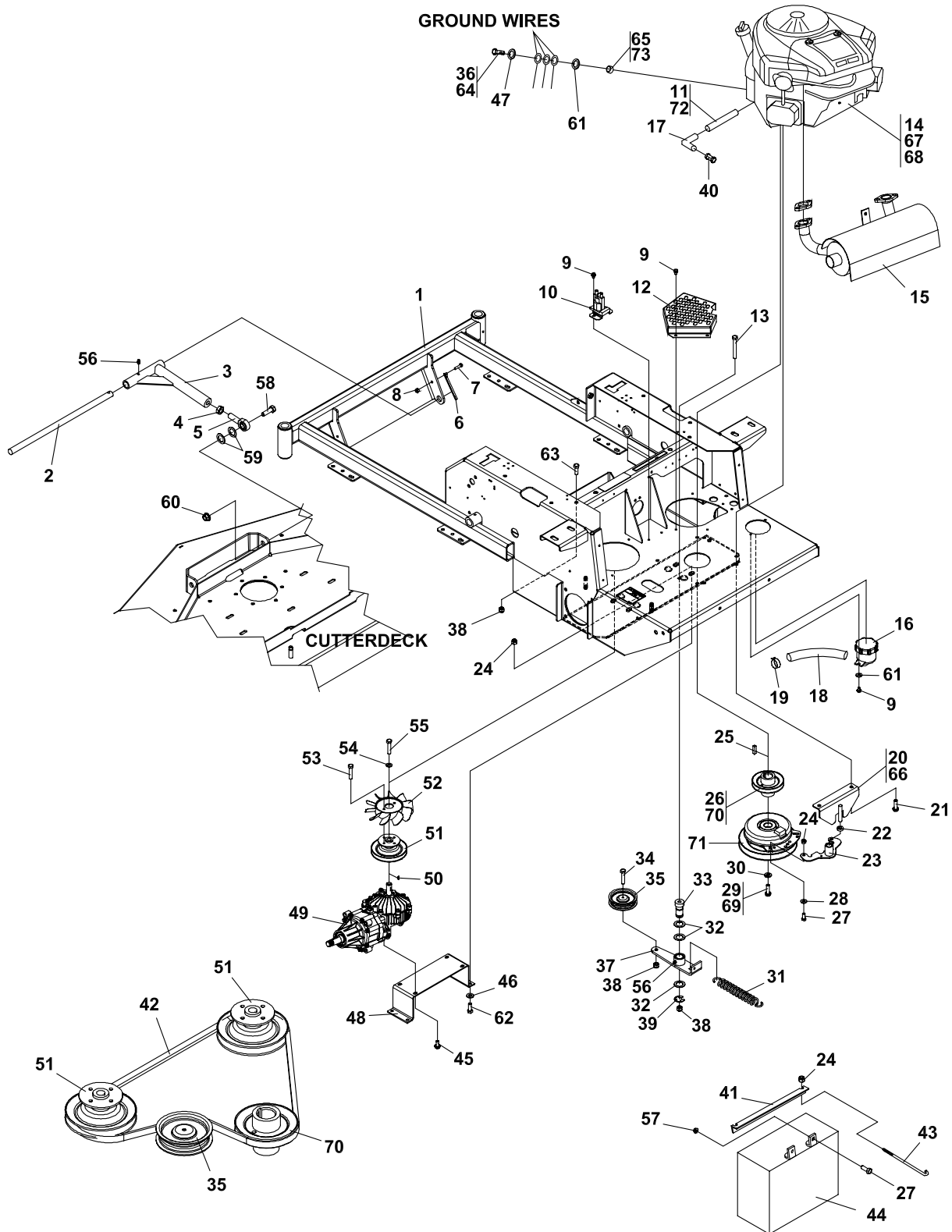

FIGURE 1

ITEM	PART NO.	DESCRIPTION	QTY	ITEM	PART NO.	DESCRIPTION	QTY
1-1	4125924	S-FRAME W/LABS, BOBCAT	1	1-41	2182427.7	HOLDDOWN-BATTERY	1
1-2	4125862	ROD-PULLARM MOUNT	1	1-42	4126312	BELT-TRCTN DRV, LEO	1
1-3	4125860.7	WLDMT-PULLARM	2	1-43	831861	BOLT,BENT BATTERY HK	2
1-4	64001-1	NUT-HEX JAM,5/8-18	2	1-44	108055	BATTERY	1
1-5	2188142-01	ROD END 5/8	2	1-45	64197-001	BLT-TDFM 5/16-18X3/4	4
1-6	64140-15	COTTER PIN-1/4-2	1	1-46	64163-29	WASHER-21/64 X 1 X 11GA	4
1-7	64123-114	BOLT-HEX 1/4-20X1	1	1-47	64006-01	LOCKWASHER-1/4 HEL	1
1-8	64229-01	LOCKNUT-NYLON 1/4-20	1	1-48	4125875.7	MOUNT-TRANSAXLE	1
1-9	64152-23	1/4-20X3/8 LG SP SCREW	11	1-49	4129341	TRANSAXLE-EATON 778	2
1-10	38665	SOLENOID	1	1-50	64164-05	KEY,WOODRUFF #404	2
1-11	48024-17A	NIPPLE-PIPE 3/8 X 5	1	1-51	4125967	PULLEY-TRANSAXLE	2
1-12	4128947.7	COVER-FAN	2	1-52	4126342	FAN	2
1-13	64123-75	BOLT, 3/8-16X3 HEX	1	1-53	64152-27	1/4-20X5/8 LG SP SCREW	9
1-14	2722010	ENG-BRIGGS INTEK 18HP	1	1-54	64163-34	WSHR.256/.267X1X11GA	2
	2722461	AIR FILTER CARTRIDGE	1	1-55	64123-07	BOLT, 1/4-20X1-1/2 HEX	2
	2722462	FOAM PRE-CLEANER	1	1-56	85010N	ZERK, 1/4-28	5
	2722463	OIL FILTER	1	1-57	64025-02	NUT-HEX 5/16-18	2
	2722464	FUEL FILTER	1	1-58	64123-168	BLT-HEX 5/8-11X2-1/2	2
	(EXHAUST BOLTS SUPPLIED WITH ENGINE)			1-59	64163-73	WSHR-.625IDX1.12ODX.062	4
1-15	2722034	MUFFLER	1	1-60	64229-06	LOCKNUT, NYLON 5/8-11	2
1-16	4129341-01	S-RESERVOIR ASSY	2	1-61	64163-03	WSHR-.256IDX.62ODX18GA	5
1-17	2690033-01	ELBOW-3/8 PIPE, 90 DEG	1	1-62	64123-68	BOLT-HEX 5/16-18X1	4
	(ITEMS 18 & 19 AVAILABLE THRU EATON)			1-63	64123-50	BOLT-HEX 3/8-16X1	2
1-18		HOSE	2	1-64	64123-89	BOLT-HEX 1/4-20X3/4	1
1-19		CLAMP	4	1-65	2722459	SPCR-.375ODX.259IDX.16LG1	1
1-20	2186147.7	WLDMT-CLUTCH BRACKET	1	1-66	4127558.7	WLDMT-CLUTCH BRKT	1
	(USED ON 18 & 25 HP MODELS ONLY)				(USED ON 17.5HP ONLY)		
1-21	64197-005	BLT-TDFM 3/8-16X1-1/4	4	1-67	4126614	ENGINE-B&S INTEK 17.5HP	1
1-22	38304-03	BRG-FLANGED PLASTIC	1		4127247	AIR FILTER	1
1-23	2721338.7	WLDMT-CLUTCH STOP	1		4127248	FOAM PRE-CLEANER	1
1-24	64229-02	LOCKNUT-NYLON 5/16-18	8		4127249	FUEL FILTER	1
1-25	64164-12	KEY-1/4X1/4X1 SQ END	1	1-68	4127681	ENG B&S 25HPW/INVERTER	1
1-26	4126201	PULLEY-ENGINE	1		2722461	AIR FILTER CARTRIDGE	1
	(USED ON 18 & 25 HP MODELS ONLY)				2722462	FOAM PRE-CLEANER	1
1-27	64123-54	BOLT, 5/16-18X3/4 HEX	4		2722463	OIL FILTER	1
1-28	64163-55	WASHER .328X.75X14 GA	2		2722464	FUEL FILTER	1
1-29	64123-78	BOLT-HEX 7/16-20X2-1/2	1		(EXHAUST BOLTS SUPPLIED WITH ENGINE)		
	(USED ON 18 & 25 HP MODELS ONLY)			1-69	64123-226	BOLT-HEX, 7/16-20 X 5	1
1-30	64006-06	LCKWSHR-HELICAL 7/16	1		(USED ON 17.5HP ONLY)		
1-31	38219	SPRING-TENSION	1	1-70	4126203	PULLEY-ENGINE, 17 HP	1
1-32	64163-65	WASHER-.890X1.375X18GA	3		(USED ON 17.5HP ONLY)		
1-33	4116691	PIN-PIVOT	1	1-71	2722016	CLUTCH-ELECTRICAL	1
1-34	64123-87	BOLT-HEX 3/8-16X1-3/4	1		(ITEMS 36, 72 & 73 USED ON 17.5HP ONLY)		
1-35	2228016	PULLEY-IDLER PUMP	1	1-72	48024-20A	NIPPLE-PIPE 3/8NPTF X 4.0	1
1-36	64123-80	BLT-HEX 1/4-20X1-1/4	1	1-73	4128580	SPACER-0.375x0.259x0.57	1
1-37	4126272.7	WLDMT-ARM IDLER LEO	1				
1-38	64229-03	LOCKNUT-NYLON 3/8-16	4				
1-39	64221-04	E-RING.875	1				
1-40	69051-01	PLUG-PIPE 3/8	1				

FUEL TANK/BUMPER & CONTROL PANEL

LEO

FIGURE 2

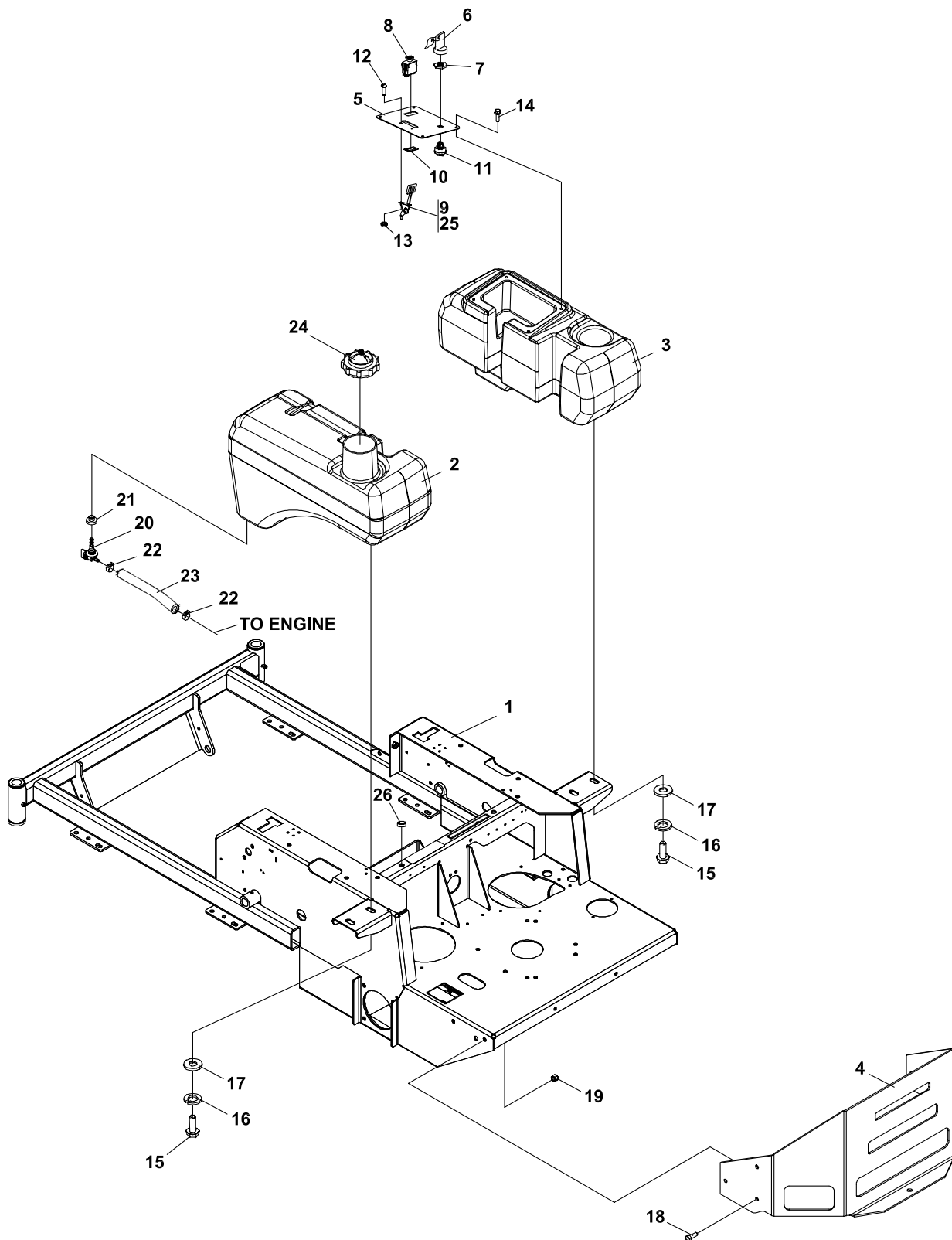

ITEM	PART NO.	DESCRIPTION	QTY	ITEM	PART NO.	DESCRIPTION	QTY
2-1	4125924	S-FRAME W/LABELS	1				
2-2	4125836	FUEL TANK-LEO	1				
2-3	4125839	FENDER-LEO	1				
2-4	4125851.7	BUMPER-LEO	1				
2-5	4127004	S-CONTROL PANEL, LEO	1				
2-6	128010-03	S-COVERED KEY	1				
2-7	128010-01	S-KEY SWITCH NUT 5/8-32	1				
2-8	2721505	SWITCH-PTO	1				
2-9	118020-14	CONTROL-THROTTLE (USED ON 20 & 25 HP MODELS ONLY)	1				
2-10	2188178	SWITCH-RETAINER	1				
2-11	128010	SWITCH, KEY	1				
2-12	64152-46	SCREW-SLT HH 10-24X1/2	2				
2-13	64025-15	NUT-HEX #10-24 KEPS	2				
2-14	64262-001	BLT-FLG HD 1/4-20 X 1/2	4				
2-15	64123-15	BOLT-3/8-16X3/4 HEX	8				
2-16	64006-03	WASHER, 3/8	8				
2-17	64163-31	WASHER, 25/64X1X12	8				
2-18	64123-50	BOLT-HEX 3/8-16X1	4				
2-19	64229-03	LOCKNUT-NYLON 3/8-16	4				
2-20	38540	VALVE-FUEL W/FILTER	1				
2-21	4132325	GROMMET-FUEL TANK	1				
2-22	88042N	HOSE CLAMP	2				
2-23	09007	HOSE.25X.5 27"	1				
2-24	2308073	CAP-FUEL TANK	1				
2-25	38357-07	CONTROL-THROTTLE (USED ON 17.5HP ONLY)	1				
2-26	810149	BUMPER-RUBBER	2				

DECK LIFT ASSEMBLY

LEO

FIGURE 3

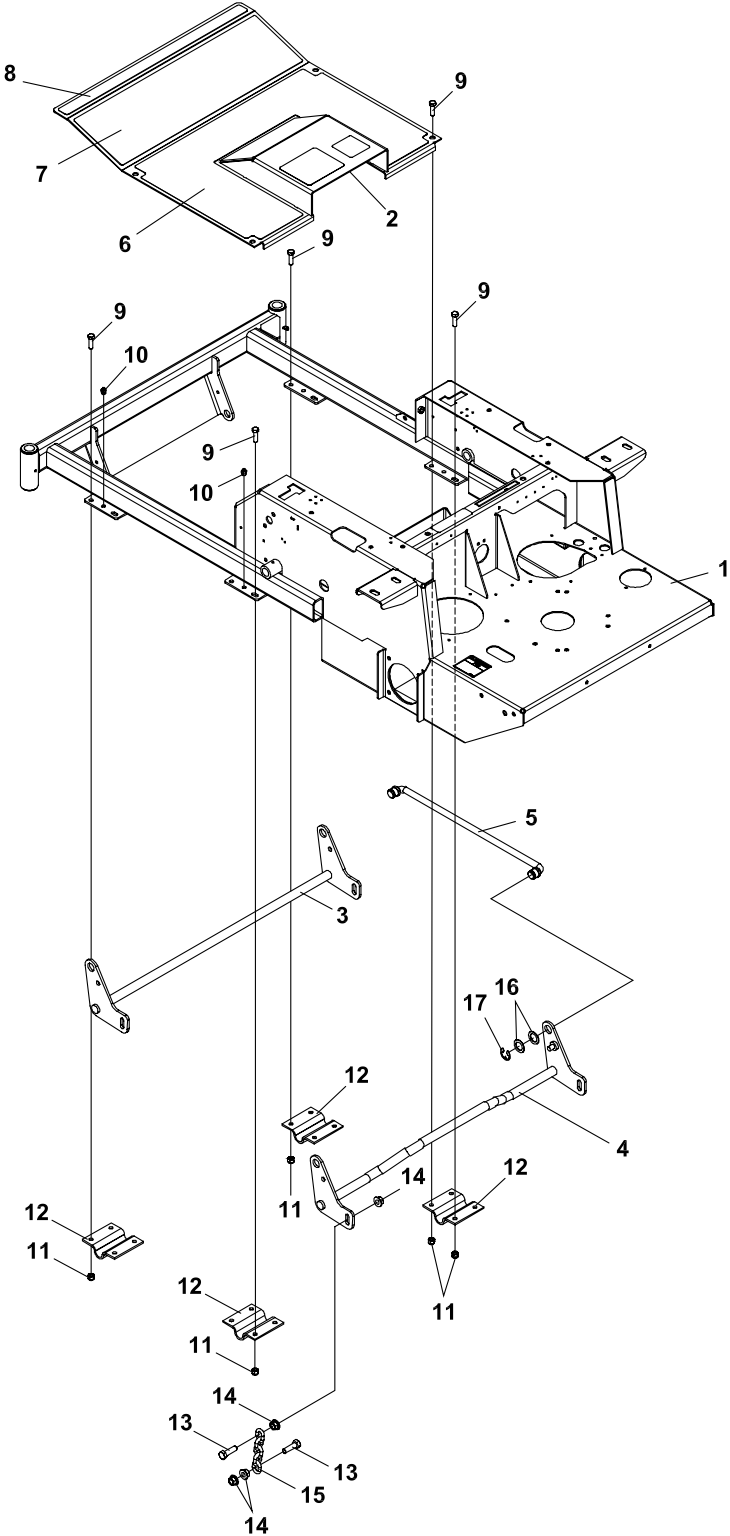

FIGURE 3

ITEM	PART NO.	DESCRIPTION	QTY	ITEM	PART NO.	DESCRIPTION	QTY
3-1	4125924	S-FRAME W/LABELS	1				
3-2	4127451	S-FOOTPLATE W/ LABELS	1				
3-3	4126355.7	WLDMT-DECKLIFT, FRONT	1				
3-4	4125855.7	WLDMT-DECKLIFT REAR	1				
3-5	4109960	WLDMT-DECK LIFT ROD	2				
3-6	4126410	MAT-FOOT PLATE, BOT	1				
3-7	4126411	MAT-FOOT PLATE, MID	1				
3-8	4126412	MAT-FOOT PLATE, TOP	1				
3-9	64123-50	BOLT-HEX 3/8-16X1	16				
3-10	85051	ZERK-1/8 PIPE	4				
3-11	64229-03	LOCKNUT-NYLON 3/8-16	16				
3-12	2182356.7	BRACKET-SHAFT HANGER	4				
3-13	64205-029	BLT-MET M12X1.75X40	8				
3-14	64246-04	NUT-WHIZ M12-1.75	16				
3-15	2188127	CHAIN-6.35 (.250) 5 LINKS	4				
3-16	64163-65	WASHER-.890X1.375X18GA	8				
3-17	64221-04	E-RING.875	4				

CASTER ASSEMBLY

LEO

FIGURE 4

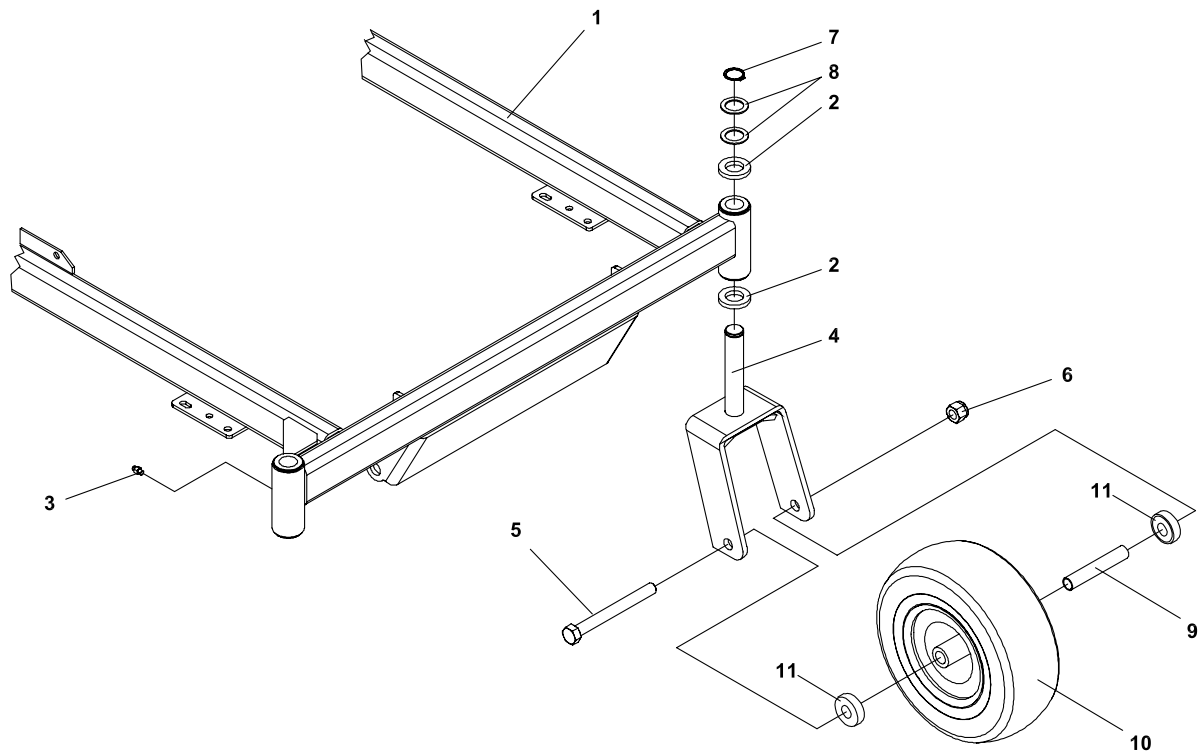
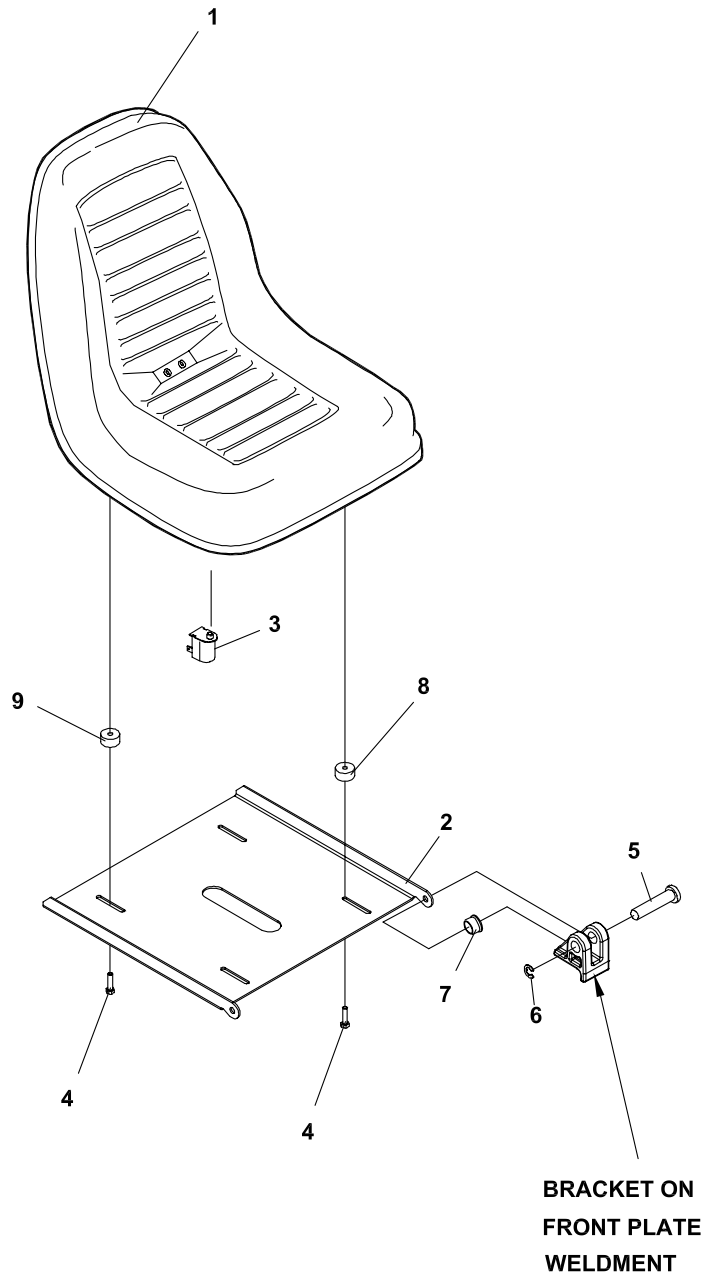

FIGURE 4

ITEM	PART NO.	DESCRIPTION	QTY	ITEM	PART NO.	DESCRIPTION	QTY
4-1	4125924	S-FRAME W/LABS, BOBCAT	1				
4-2	64163-07	WASHER, 1-1/32X1-3/4X1/4	4				
4-3	85010N	ZERK, 1/4-28	2				
4-4	2722443.7	WLDMT-CASTER YOKE	2				
4-5	64123-212	BOLT-5/8-11X6.00	2				
4-6	64229-06	LOCKNUT, NYLON 5/8-11	2				
4-7	64144-24	SNAP RING 1.00 EXT	2				
4-8	64163-64	WSHR 1.015X1.500X14GA	4				
4-9	2722230-01	SPANNER-11" WHEEL	2				
4-10	2722233	WHEEL-11"ASSY	2				
4-11	2722231	SPACER-END	4				

FIGURE 5



LEO

SEAT ASSEMBLY

FIGURE 5

ITEM	PART NO.	DESCRIPTION	QTY	ITEM	PART NO.	DESCRIPTION	QTY
5-1	4126406	SEAT-LEO	1				
5-2	4126075.7	PLATE-SEAT	1				
5-3	4124009	SWITCH-SEAT NO	1				
5-4	64139-10	BLT-WLF 5/16-18X1-1/4	4				
5-5	33138-09	PIN-CLEVIS	2				
5-6	64144-30	SNAP RING	2				
5-7	38371-01	BRG-NYLINER 3/8	2				
5-8	2720975-06	SPACER-NYLON 5/8"	2				
5-9	2720975-07	SPACER-NYLON 3/8"	2				

FIGURE 6

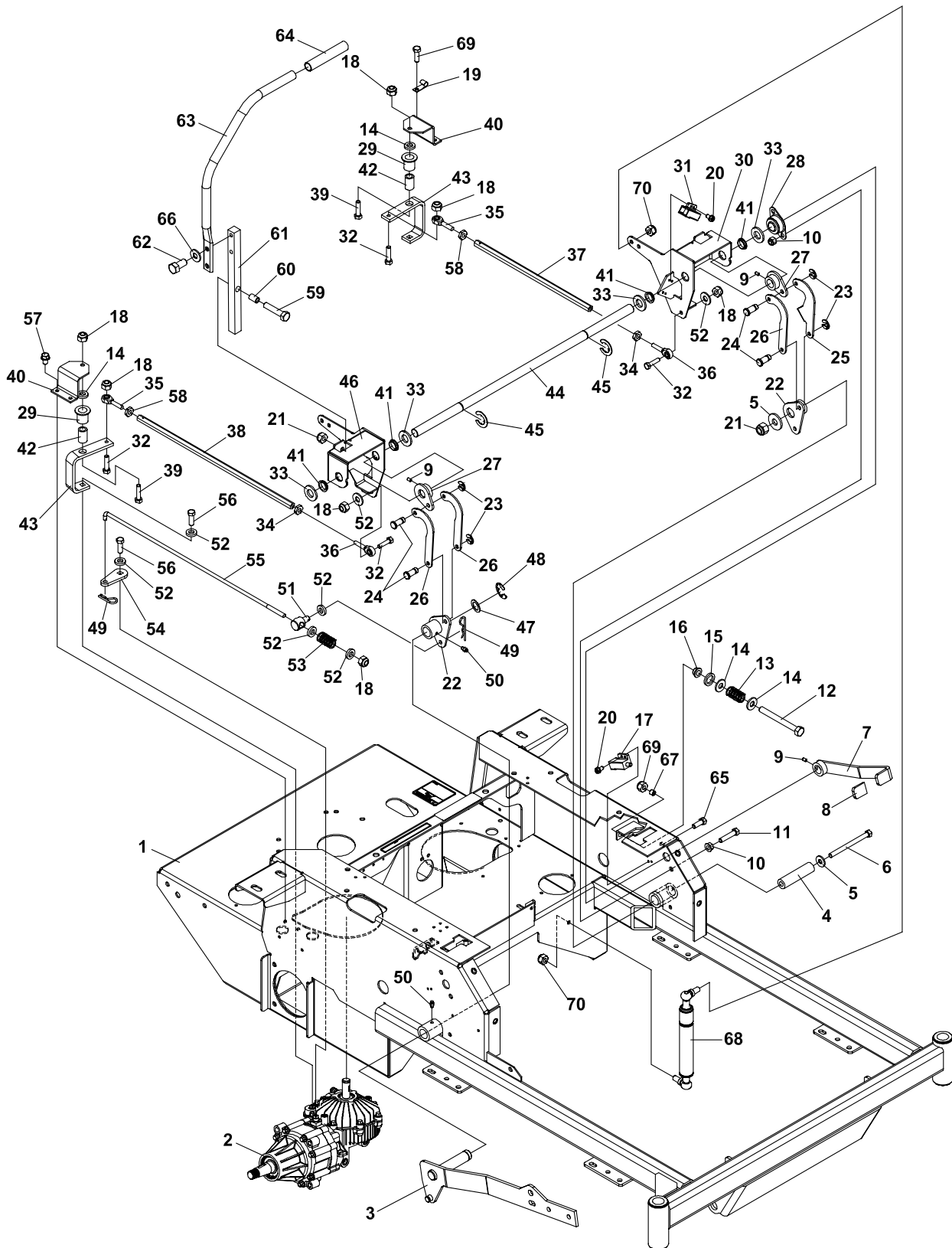

FIGURE 6

ITEM	PART NO.	DESCRIPTION	QTY	ITEM	PART NO.	DESCRIPTION	QTY
6-1	4125924	S-FRAME W/LABELS	1	6-51	4126382	SWIVEL-NON-THREAD	2
6-2	4129341	TRANSAXLE-EATON 778	2	6-52	64163-02	WSR.321/.328X.593/.608X11	8
6-3	4125854.7	WLDMT-DECKLIFT LEVER	1	6-53	4126872	SPRING-BRAKE	2
6-4	4126351	BSHG-LH BRAKE	1	6-54	4125869	ARM-BRAKE	2
6-5	64163-51	WSHR.453X1.38X7GA	3	6-55	4125878	ROD-BRAKE	2
6-6	64123-173	BLT-HEX 3/8-16X4-1/2	1	6-56	64123-116	BLT-HEX 1/4-28X3/4	4
6-7	4125853.7	WLDMT-BRAKE ARM	1	6-57	64152-23	1/4-20X3/8 LG SP SCREW	4
6-8	2188155	GRIP, 1/4X1X4-1/2	1	6-58	64025-03	NUT-HEX 5/16-24	2
6-9	64044-5	SCREW-SET 1/4-20X3/8	3	6-59	64123-70	BOLT-HEX 3/8-16X1-1/2	2
6-10	64141-4	NUT-WLF 3/8-16	5	6-60	2183073	SPACER	2
6-11	64123-87	BOLT-HEX 3/8-16X1-3/4	1	6-61	4126350	BAR-HANDLE	2
6-12	64123-205	BLT-HEX 5/16-24X4	2	6-62	64123-50	BOLT-HEX 3/8-16X1	4
6-13	2188139	SPRING-COMPRESSION	2	6-63	4122172.7	LEVER-TRACTION CNTRL	2
6-14	64163-55	WASHER .328X.75X14 GA	6	6-64	2188144	GRIP,.75ID X 12	2
6-15	64163-54	.516X.75X12GA THK WSHR	2	6-65	64123-15	BOLT-3/8-16X3/4 HEX	3
6-16	38304-02	BRG, FLGD PLASTIC	2	6-66	64006-06	LOCKWSHR-HEL 7/16	4
6-17	2188156	SWITCH-NONO DBL POLE	1	6-67	103044	SPACER	2
6-18	64229-02	LOCKNUT-NYLON 5/16-18	8	6-68	2721246	DAMPENER	2
6-19	48412-01	CLIP-3/4 J X 10.32 HOLE	1	6-69	64229-08	LOCKNUT-5/16-24	2
6-20	64197-015	BLT-TDFM 10-32X1/2 TORX	6	6-70	64237-05	LOCKNUT-M8-1.25	4
6-21	64229-03	LOCKNUT-NYLON 3/8-16	3				
6-22	4125876.7	WLDMT-BRAKE BELLCRNK	2				
6-23	64144-31	SNAP RING.312	4				
6-24	33138-01	PIN,CLEVIS GRVD	4				
6-25	4126842.7	PLATE-BRAKE, OUTER	1				
6-26	4126074.7	PLATE-BRAKE	3				
6-27	4126501.7	WLDMT-BRAKE CONTROL	2				
6-28	2188145	BEARING-.75ID BRZ	2				
6-29	4127141	BSHG-PUMP ARM	2				
6-30	4129267.7	WLDMT-LH CONTROL	1				
6-31	108208	SWITCH DBL POLE	2				
6-32	64123-47	BLT-HEX 5/16-18X1-1/4	4				
6-33	64163-06	WASHER.768/.756X1.25X14	2				
6-34	64025-33	NUT-HEX 5/16-24 LH	2				
6-35	38369-01	ROD END BALL JOINT RH	2				
6-36	38369-02	ROD END BALL JOINT LH	2				
6-37	2188140-1	TURNBUCKLE	1				
6-38	2188140-2	TURNBUCKLE	1				
6-39	64123-69	BOLT-5/16-18X1-1/2 HEX	2				
6-40	4126517.7	BRKT-PUMP ARM SPPRT	2				
6-41	4127142	BSHG-CONTROL ARM	4				
6-42	2721955	SPACER-8.74X12.7X20 LG	2				
6-43	4126419	ARM-PUMP CONTROL	2				
6-44	4125872	ROD-CONTROL	1				
6-45	64221-03	E-CLIP	2				
6-46	4129268.7	WLDMT-RH CONTROL	1				
6-47	64163-65	WASHER-.890X1.375X18GA	1				
6-48	64221-04	E-RING.875	1				
6-49	64168-2	COTTER-HAIRPIN.08X1.19	4				
6-50	85010N	ZERK, 1/4-28 STR SF THRD	3				

* NOT ILLUSTRATED

WIRE HARNESS

LEO

FIGURE 7

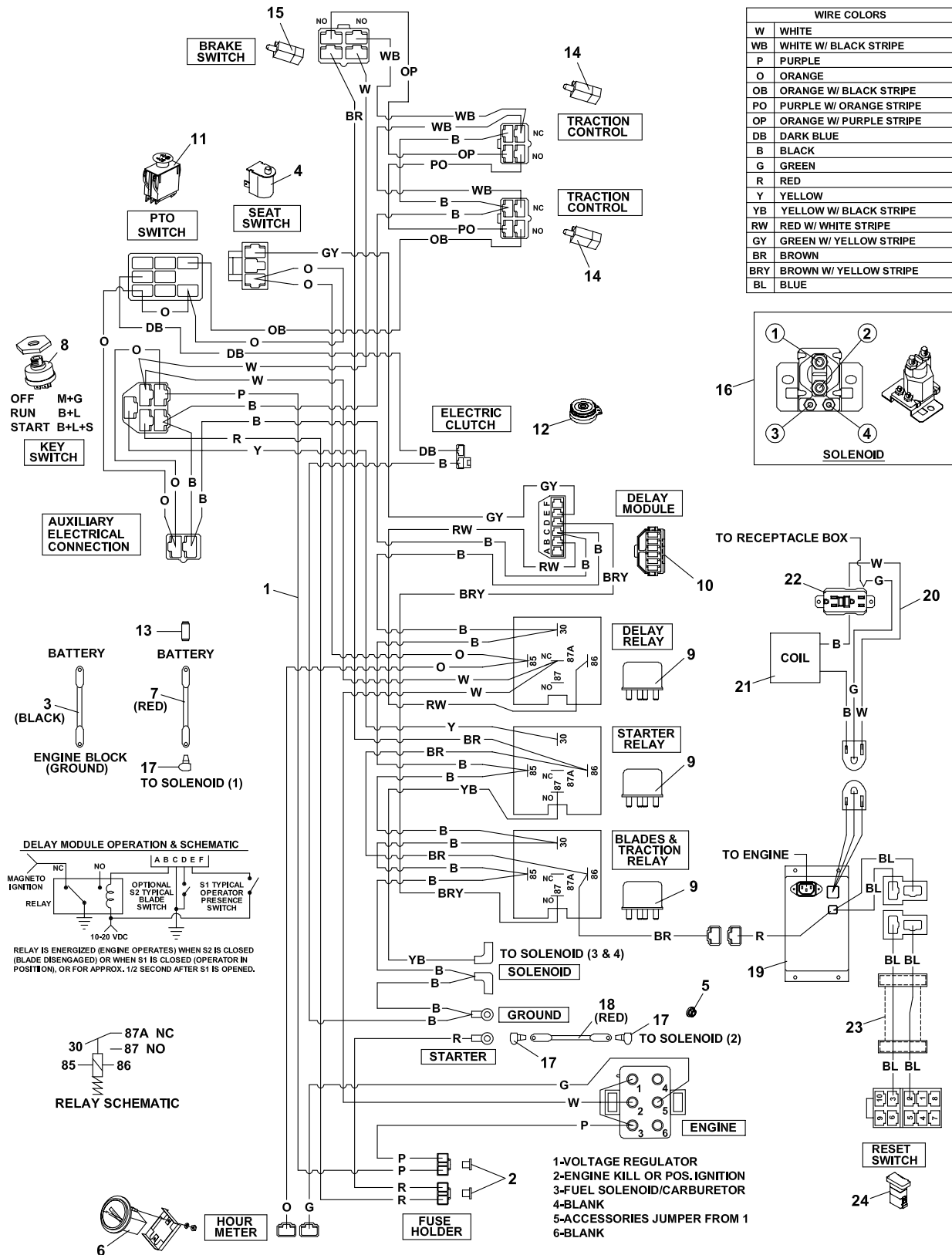

FIGURE 7

ITEM	PART NO.	DESCRIPTION	QTY	ITEM	PART NO.	DESCRIPTION	QTY
7-1	4127204	WIRE HARNESS-LEO	1				
7-2	148082-20	FUSE 20 AMP	2				
7-3	108061-13	CABLE-BATTERY 36 BLK	1				
7-4	4124009	SWITCH-SEAT NO	1				
7-5	64141-2	NUT-WLF 1/4-20	1				
7-6	48030N	HOUR METER ASSY	1				
7-7	2722227-01	CABLE-BATTERY (INCLUDES ITEMS 17 & 20)	1				
7-8	128010	SWITCH, KEY	1				
7-9	2722325	RELAY-40AMP SEALED	3				
7-10	2188154	MODULE-DELAY	1				
7-11	2721505	SWITCH-PTO	1				
7-12	2722016	CLUTCH-ELECTRICAL	1				
7-13	112386	BOOT,BAT TERM POS	1				
7-14	108208	SWITCH DBL POLE	2				
7-15	2188156	SWITCH-NONO DBL POLE	1				
7-16	38665	SOLENOID	1				
7-17	2308095	COVER-TERMINAL	3				
7-18	108061-04	CABLE-BATTERY 20 RED	1				
(ITEMS 19-24 USED ON 25HP MODEL ONLY)							
7-19	4127676	MODULE-POWERLINK	1				
7-20	4127677	MODULE-POWERLINK OUT (INCLUDES ITEMS 20 & 21)	1				
7-21	4127677-01	COIL	1				
7-22	4127677-02	GFCI RECEPTACLE	1				
7-23	4127678	CONNECT-OUTLET SWITCH	1				
7-24	2721815	SWITCH-LIGHT	1				

DECK LIFT/REAR WHEEL

LEO

FIGURE 8

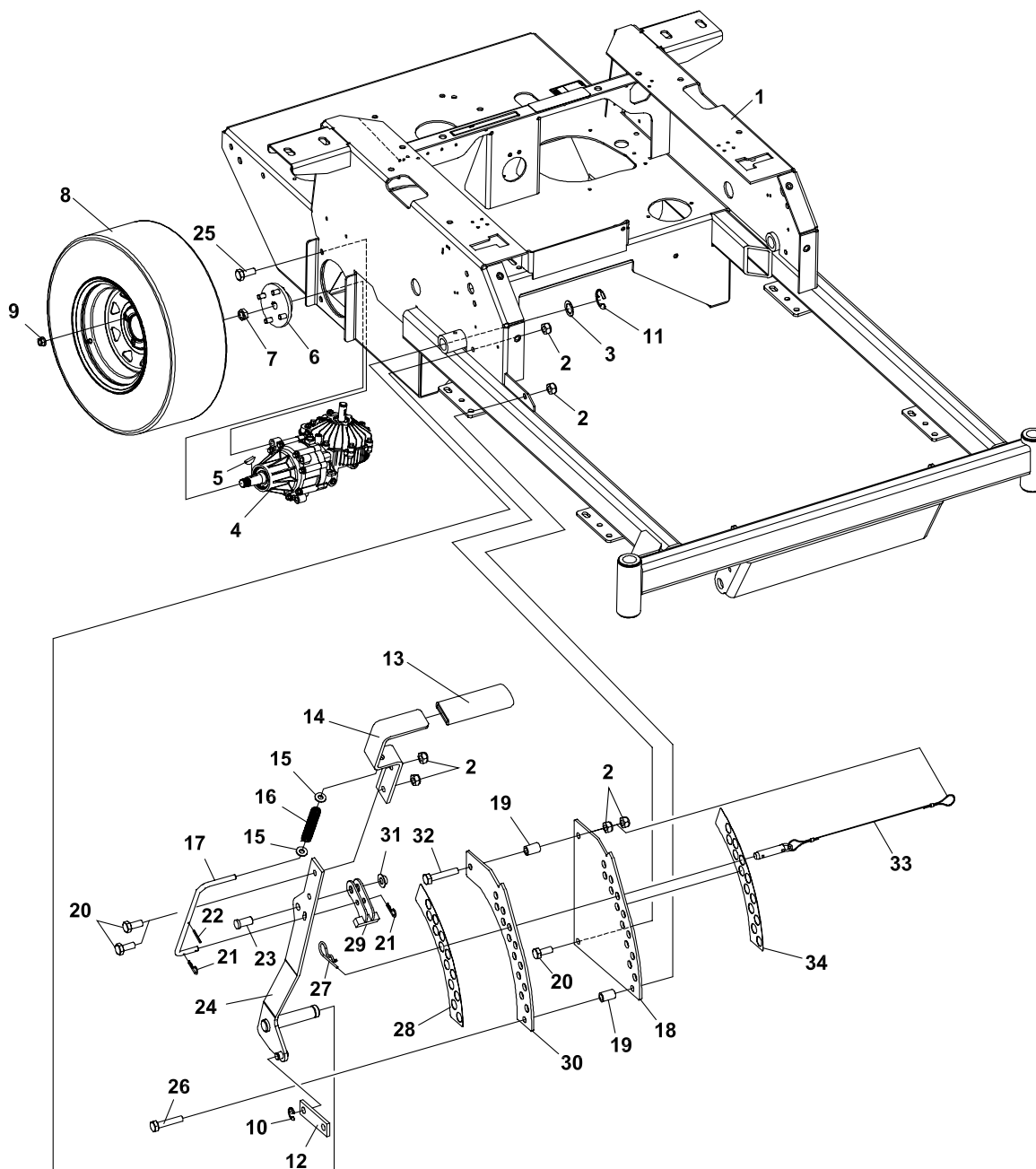

ITEM	PART NO.	DESCRIPTION	QTY	ITEM	PART NO.	DESCRIPTION	QTY
8-1	4125924	S-FRAME W/LABELS	1				
8-2	64229-03	LOCKNUT-NYLON 3/8-16	6				
8-3	64163-65	WASHER-.890X1.375X18GA	1				
8-4	4129341	TRANSAXLE-EATON 778	2				
8-5	64164-28	KEY-#808 WOODRUFF	2				
8-6	4126353.7	ASSY-WHEEL HUB	2				
8-7	64025-37	NUT-SLOTTED HEX 3/4-20	2				
8-8	4126311	ASY-WHL&TIRE23X8.50-12	2				
8-9	64187-03	WHEEL NUT 1/2-20	8				
8-10	64144-34	SNAP RING.50	1				
8-11	64221-04	E-RING.875	1				
8-12	4126687.7	BRKT-LIFT LINK, LEO	1				
8-13	2188143	GRIP	1				
8-14	2720501.7	LEVER-DECK LIFT	1				
8-15	64163-29	WASHER-21/64 X 1 X 11GA	2				
8-16	2720544	SPRING-COMPRESSION	1				
8-17	2720503	ROD-LIFT STOP	1				
8-18	2720516.7	BRKT-OUTER DECK LIFT	1				
8-19	2183071-03	SPACER-15.88X10.32X24	2				
8-20	64123-50	BOLT-HEX 3/8-16X1	3				
8-21	64168-2	COTTER-HAIRPIN.08X1.19	2				
8-22	64061-37	ROLL PIN-1/8X1.00	1				
8-23	64188-53	PIN-CLEVIS 1/2X1.0	1				
8-24	4125854.7	WLDMT-DECKLIFT LEVER	1				
8-25	64197-003	BLT-TDFM 3/8-16X1.00	8				
8-26	64123-67	BLT-HEX 3/8-16X2	1				
8-27	64168-1	COTR-HAIRPIN.120X2-3/8	1				
8-28	4126611	LABEL-H.O.C. OUTER, LEO	1				
8-29	2720511.7	WLDMT-LVR STOP LATCH	1				
8-30	2720517.7	BRKT-INNER DECK LIFT	1				
8-31	64175-05	PUSHNUT-1/2 DIA	1				
8-32	64123-82	BOLT-HEX 3/8-16X2-1/2	1				
8-33	2188141	ASSY, PIN & LANYARD	1				
8-34	2720743	LBL-ZT200 HT CUT INNER	1				

KICKPLATE ASSEMBLY

LEO

FIGURE 9

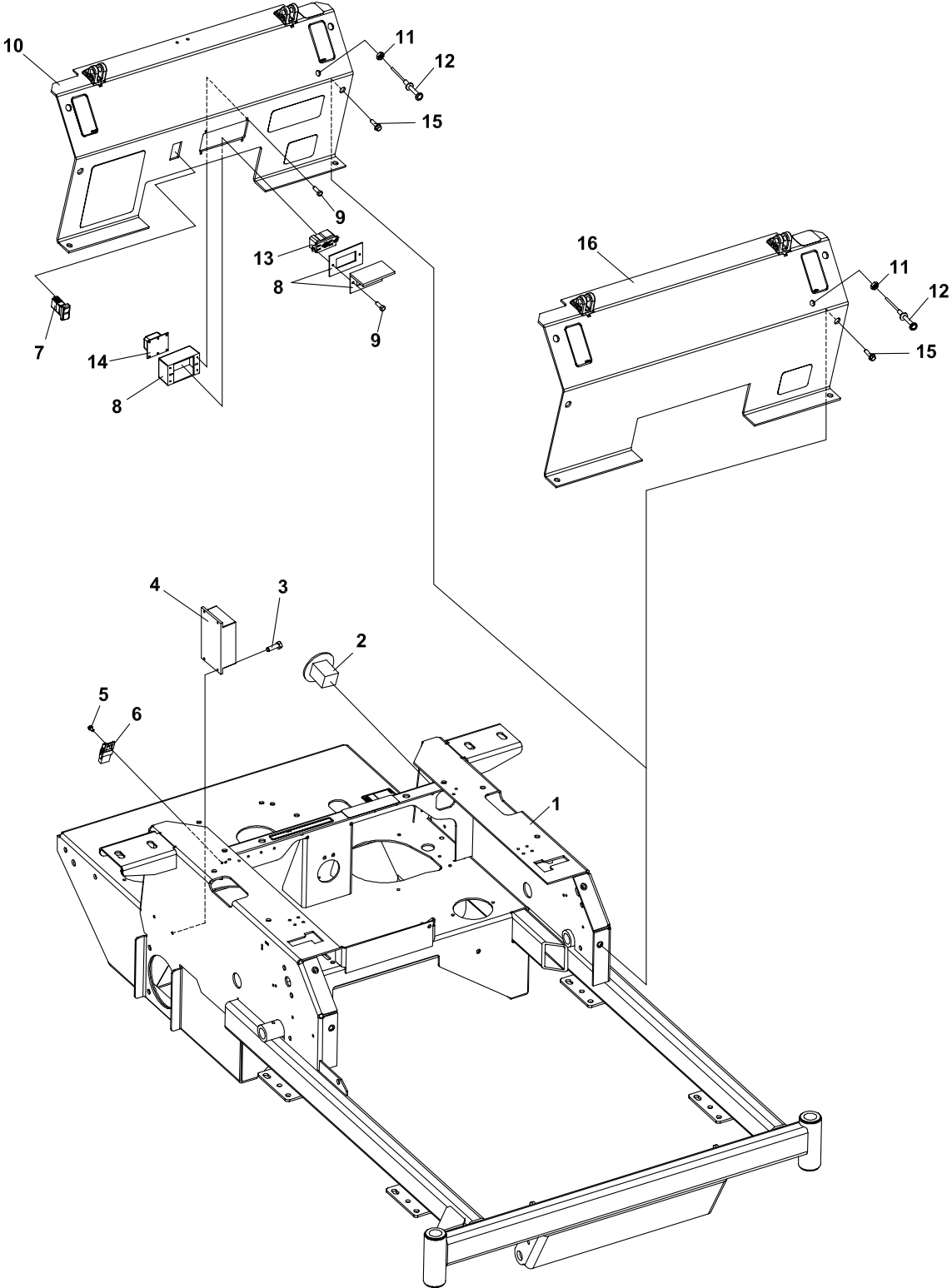

FIGURE 9

ITEM	PART NO.	DESCRIPTION	QTY	ITEM	PART NO.	DESCRIPTION	QTY
9-1	4125924	S-FRAME W/LABELS	1				
9-2	48030N	HOUR METER ASSEMBLY	1				
		(ITEMS 3 & 4 USED ON 25HP ONLY)					
9-3	64152-27	1/4-20X5/8 LG SP SCREW	4				
9-4	4127676	MODULE-POWERLINK	1				
9-5	64197-015	BLT-TDFM 10-32X1/2	2				
9-6	2188154	MODULE-DELAY	1				
		(ITEMS 7-10, 17 & 18 USED ON 25HP ONLY)					
9-7	2721815	SWITCH-LIGHT	1				
9-8	4127677	MODULE-POWERLINK (INCLUDES ITEMS 17 & 18)	1				
9-9	64152-60	SCREW-#6-32 X 1/2	6				
9-10	4127285	S-FRONT PLATE	1				
		(ITEMS 11 & 12 NOT USED ON 17.5HP)					
9-11	64025-04	NUT-3/8-24 HEX	1				
9-12	108009-07	CONTROL-CHOKE, 59	1				
9-13	4127677-02	GFCI RECEPTACLE	1				
9-14	4127677-01	COIL	1				
9-15	64262-010	BLT-FLG HD 3/8-16 X 3/4	4				
9-16	4127455	S-FRONT PLATE (USED ON 17.5 & 20HP MODELS)	1				

48" SIDE DISCHARGE

LEO

FIGURE 10

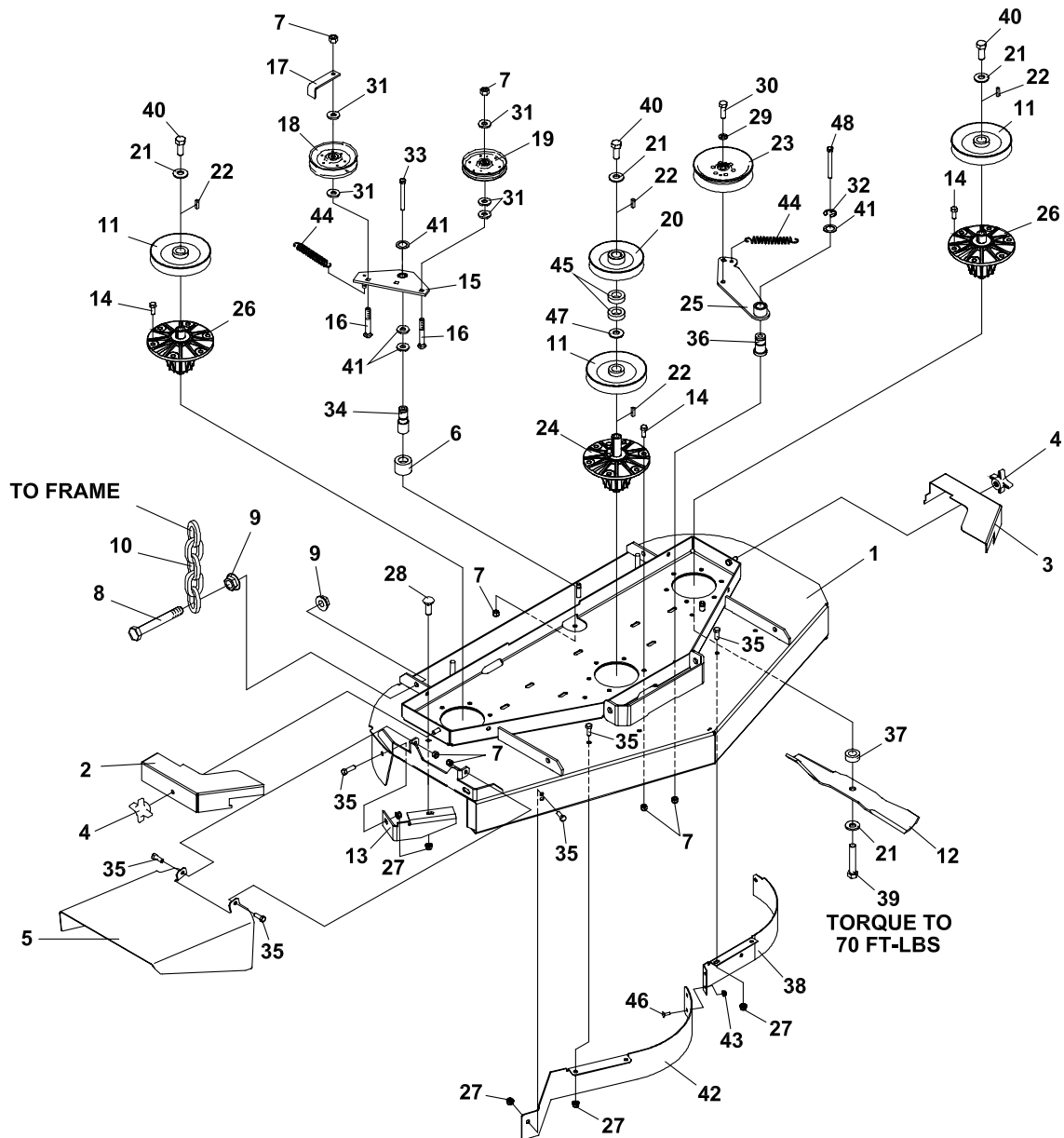

ITEM	PART NO.	DESCRIPTION	QTY	ITEM	PART NO.	DESCRIPTION	QTY
10-1	4126522	S-48 CUTTERDECK W/LABS	1				
10-2	4127852.2	COVER-BELT, 48 LH	1				
10-3	4127853.2	COVER-BELT, 48 RH					
10-4	38524	KNOB-4 PRONG 3/8-16	2				
10-5	32723.2	CHUTE-DISCHARGE	1				
10-6	4127293	SPACER-IDLER	1				
10-7	64229-03	LOCKNUT-NYLON 3/8-16	24				
10-8	64205-029	BLT-MET M12X1.75X40	8				
10-9	64246-04	NUT-WHIZ M12-1.75	16				
10-10	2188127	CHAIN-6.35 (.250) 5 LINKS	4				
10-11	2308140	PULLEY-ENGINE	3				
10-12	112111-01	BLADE 16.25 OFFST HLFT	3				
10-13	4120208.7	BAFFLE-DISCHARGE 32-48	1				
10-14	64262-012	BLT-FLG HD 3/8-16 X 1-1/4	18				
10-15	4121584.7	WLDMT-IDLER ARM	1				
10-16	64018-18	BOLT-CARRIAGE 3/8-16X2	2				
10-17	2302125.7	GUIDE-BELT	1				
10-18	48393	PULLEY-V IDLER	1				
10-19	38297	IDLER, 5 OD FLANGED	1				
10-20	2228034	PULLEY-5.25 DEEP GRV	1				
10-21	64209-03	SPRING WASHER.67 ID	6				
10-22	64164-12	KEY-1/4X1/4X1 SQ END	4				
10-23	128169	PULLEY, IDLER 5.50	1				
10-24	4127295	S-ASSY SPINDLE, CENTER	1				
10-25	4110580.7	WLDMT-DECK IDLER	1				
10-26	4115850	S-ASSY SPINDLE OUTER	2				
10-27	64268-03	NUT-FL NYL LOCK 3/8-16	8				
10-28	64018-3	BOLT-3/8-16X1 CARRIAGE	1				
10-29	64006-05	LOCKWSHR-HELICAL 1/2	1				
10-30	64123-05	BLT-HEX 1/2-20X1-1/2	1				
10-31	64163-46	WASHER.383/.393X.88X7GA	5				
10-32	64221-04	E-RING.875	2				
10-33	64123-93	BLT-HEX 3/8-16X5	1				
10-34	4116712	PIN-PIVOT	1				
10-35	64123-50	BOLT-HEX 3/8-16X1	9				
10-36	4116661	PIN-PIVOT	1				
10-37	4118314	SPACER-BLADE	3				
10-38	4120175.7	BAFFLE-48 FRONT LH	1				
10-39	64123-187	BLT-HEX 5/8-18 X 3 3/4	3				
10-40	64123-208	BLT-HEX 5/8-18X1.5	3				
10-41	64163-65	WASHER-.890X1.375X18GA	4				
10-42	4120180.7	BAFFLE-48 FRONT RH	1				
10-43	64268-01	NUT-FL NYL LOCK 1/4-20	2				
10-44	2188131	SPRING-EXTENSION	2				
10-45	64163-22	1-1/32X1-3/4X1/2 WASHR	2				
10-46	64018-2	BLT-CRG 1/4-20X3/4	2				
10-47	64163-68	WSHR-1.015X1.5X9GA	1				
10-48	64123-88	BOLT, 3/8-16X2-3/4	1				

52" SIDE DISCHARGE

LEO

FIGURE 11

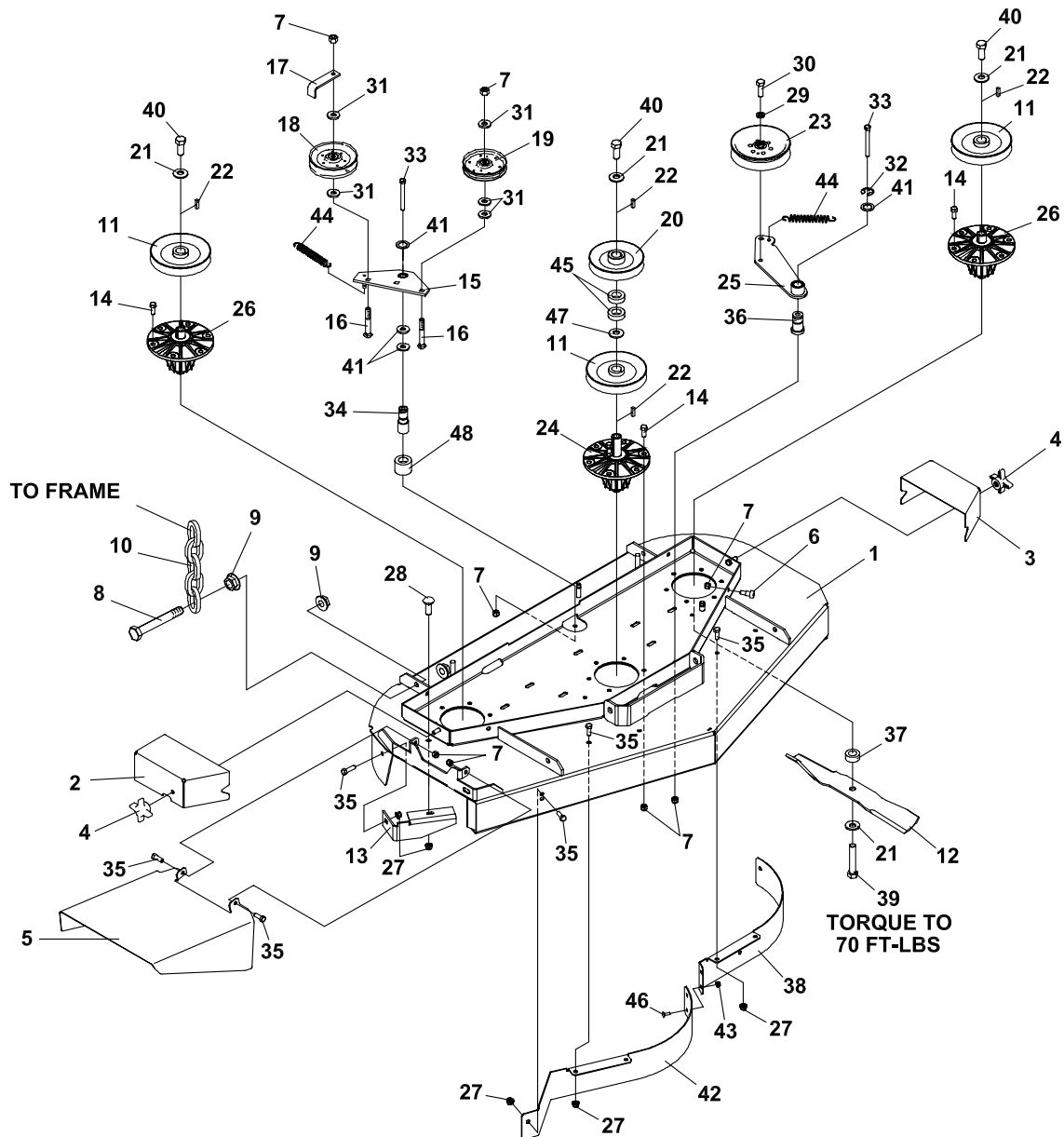

FIGURE 11

ITEM	PART NO.	DESCRIPTION	QTY	ITEM	PART NO.	DESCRIPTION	QTY
11-1	4126526	S-52 DECK W/LABS	1				
11-2	2722574.2	COVER-BELT RH	1				
11-3	2722575.2	COVER-BELT LH	1				
11-4	38524	KNOB-4 PRONG 3/8-16	2				
11-5	32723.2	CHUTE-DISCHARGE	1				
11-6	64166-17	BLT-SHLDR 3/8-16X1.12	4				
11-7	64229-03	LOCKNUT-NYLON 3/8-16	28				
11-8	64205-029	BLT-MET M12X1.75X40	8				
11-9	64246-04	NUT-WHIZ M12-1.75	16				
11-10	2188127	CHAIN-6.35 (.250) 5 LINKS	4				
11-11	2308140	PULLEY-ENGINE	3				
11-12	112111-02	BLADE 18.00 OFFST HLFT	3				
11-13	4115864.7	BAFFLE-DISCHARGE	1				
11-14	64262-012	BLT-FLG HD 3/8-16 X 1-1/4	18				
11-15	4121584.7	WLDMT-PTO IDLER	1				
11-16	64018-18	BOLT-CARRIAGE 3/8-16X2	2				
11-17	2302125.7	GUIDE-BELT	1				
11-18	48393	PULLEY-V IDLER	1				
11-19	38297	IDLER, 5 OD FLANGED	1				
11-20	2228034	PULLEY-5.25 DEEP GRV	1				
11-21	64209-03	SPRING WASHER.67 ID	6				
11-22	64164-12	KEY-1/4X1/4X1 SQ END	4				
11-23	128169	PULLEY, IDLER 5.50	1				
11-24	4127295	S-ASSY SPINDLE, CENTER	1				
11-25	4110580.7	WLDMT-IDLER	1				
11-26	4115850	S-ASSY SPINDLE OUTER	2				
11-27	64268-03	NUT-FL NYL LOCK 3/8-16	8				
11-28	64018-3	BOLT-3/8-16X1 CARRIAGE	1				
11-29	64006-05	LOCKWSHR-HELICAL 1/2	1				
11-30	64123-05	BLT-HEX 1/2-20X1-1/2	1				
11-31	64163-46	WASHER.383/.393X.88X7GA	5				
11-32	64221-04	E-RING.875	2				
11-33	64123-93	BLT-HEX 3/8-16X5	1				
11-34	4116712	PIN-PIVOT	1				
11-35	64123-50	BOLT-HEX 3/8-16X1	9				
11-36	4116661	PIN-PIVOT	1				
11-37	4118314	SPACER-BLADE 16MM	3				
11-38	4118427.7	BAFFLE-FRONT LH	1				
11-39	64123-187	BLT-HEX 5/8-18 X 3 3/4	3				
11-40	64123-208	BLT-HEX 5/8-18X1.5	3				
11-41	64163-65	WASHER-.890X1.375X18GA	4				
11-42	4118428.7	BAFFLE-FRONT RH	1				
11-43	64268-01	NUT-FL NYL LOCK 1/4-20	2				
11-44	2188131	SPRING-EXTENSION	2				
11-45	64163-22	1-1/32X1-3/4X1/2 WASHR	2				
11-46	64018-2	BLT-CRG 1/4-20X3/4	2				
11-47	64163-68	WSHR-1.015X1.5X9GA	1				
11-48	4127293	SPACER-IDLER	1				
11-49	64123-88	BOLT, 3/8-16X2-3/4	1				

FIGURE 12

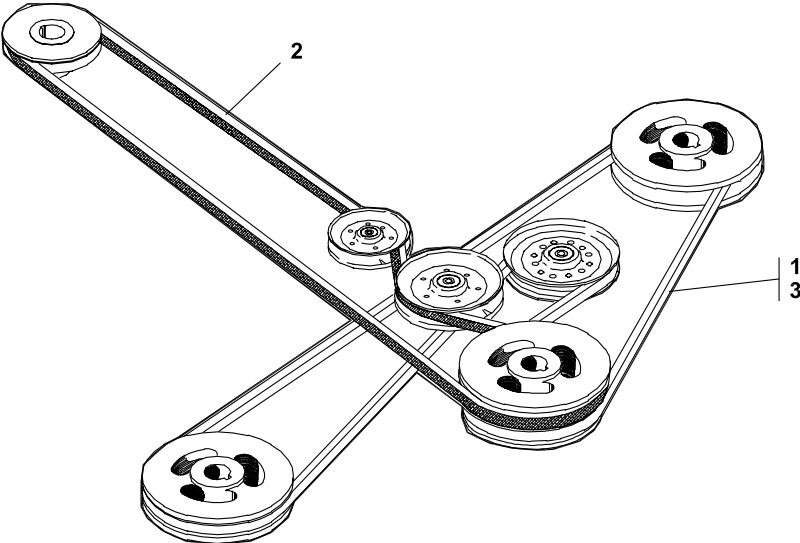
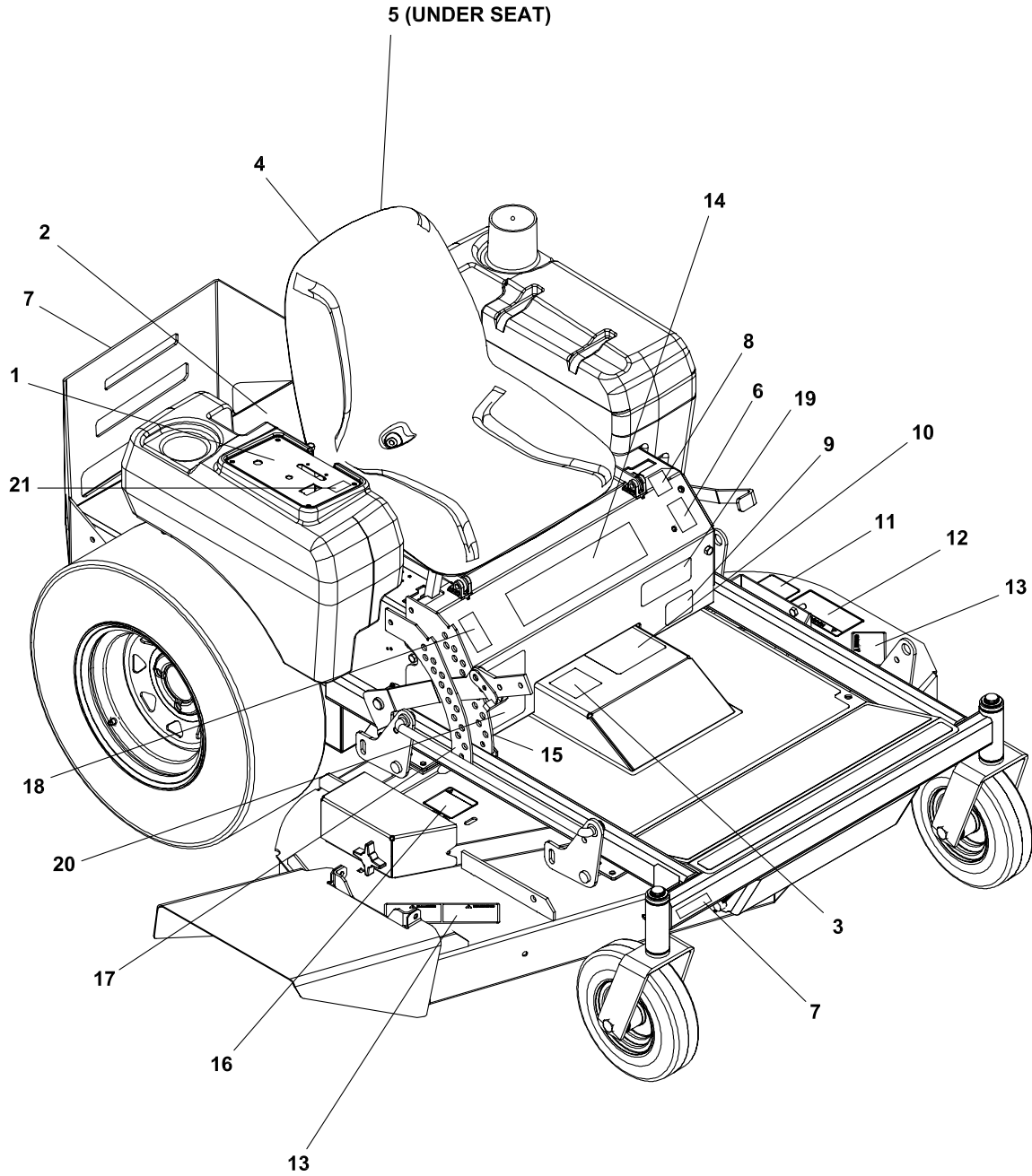

FIGURE 12

ITEM	PART NO.	DESCRIPTION	QTY	ITEM	PART NO.	DESCRIPTION	QTY
12-1	2188176	BELT-CUTTERDECK 52 (USED ON 52" DECKS)	1				
12-2	2720815	BELT-PTO 48	1				
12-3	128110	BELT-CUTTER DECK (USED ON 48" DECKS)	1				

FIGURE 13



ITEM	PART NO.	DESCRIPTION	QTY	ITEM	PART NO.	DESCRIPTION	QTY
13-1	4126803	LABEL-CONTROL PANEL	1				
13-2	2000570	LABEL-WARN FUEL PICT.	1				
13-3	340830	DECAL, CAUTION	1				
13-4	4124262	LABEL-BOBCAT	1				
13-5	2000590	LABEL, WARN BATTERY	1				
13-6	2000701	LABEL - LH TRACTION	1				
13-7	4126849	LABEL-LEO	2				
13-8	4126804	LABEL-PARKING BRAKE	1				
13-9	4126802	LABEL-TIRE PRESSURE	1				
13-10	4118843	LABEL-WARNING	1				
13-11	2000696	LABEL - BLADE INSTALL	1				
13-12	2000572	LABEL-WARNING BLADES	1				
13-13	2000677	LABEL-DANGER/WARNING	2				
13-14	4126850	LABEL-KICKPLATE, LEO	1				
13-15	2720743	LABEL-ZT200 HOC INNER	1				
13-16	2000577	LABEL, WARNING	3				
13-17	4126611	LABEL-H.O.C. OUTER	1				
13-18	2000700	LBL - RH TRACTION	1				
(ITEMS 19 & 20 USED ON 25HP ONLY)							
13-19	4127996	LABEL-POWERLINK	1				
13-20	4127984	LABEL-WARNING, ELECTR.	1				
13-21	4128578	LABEL-CHOKE (USED ON 17.5 HP ONLY)	1				

World Class Quality, Performance And Support



Equipment from Jacobsen, a Textron company, is built to exacting standards ensured by ISO 9001 and ISO 14001 registration at all our manufacturing locations.

A worldwide dealer network and factory-trained technicians backed by Textron Parts Xpress provide reliable, high-quality product support.



BOB-CAT BROWER BUNTON CUSHMAN RYAN STEINER